

GEMINI 100 DUAL EDGE
230-240V / 50Hz

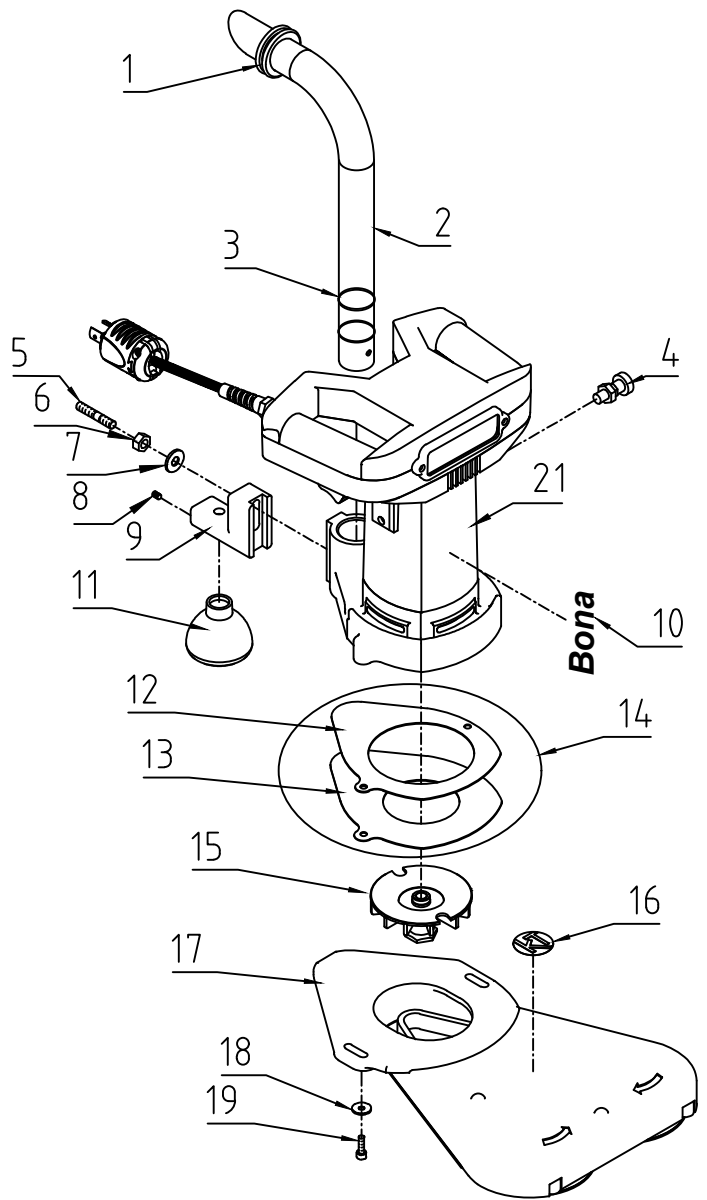

GEMINI 100 DUAL EDGE
115V / 60Hz

6899950002BKT - GEMINI 100 DUAL EDGE 230V/50Hz RAL 9006

6899950006BKT - GEMINI 100 DUAL EDGE 115V/60Hz RAL 9006



KUNZLE & TASIN
Via MARZABOTTO 63-20037-PADERNO DUGNANO (MI)
TEL.: 02/66040930 FAX: 02/66013445

GEMINI 100 Dual Edge

230-240V/50Hz - 115V/60Hz

KT-BONA

PAGE 1/7

MAY 2022

PARTS LIST

EL.	PART NUMBER	DESCRIPTION	N°
1	6600030095	DUST BAG BLACK HOLDING RING ART2355	2
2	6600030086	SUCTION PIPE N2/G	1
3	5803431008	O RING GASKET 4137	2
4	5100031180	PLUNGER GN 617-5-AK	1
5	2500030009	STUD BOLT M8x37 GALVANIZED	1
6	5801930008	NUT UNI 5588 M8	1
7	5802234001	RING UNI 6593-69 9x24	1
8	5801531002	CONE P.GRUB SCREW 5MAX10 UNI5927	1
9	6800040004NO	SPH.WHEEL REAR MATT BLACK SUPPORT-G	1
10	5100031297	BONA WHITE LABEL 111X29	1
11	SN9995035N0BH00	BLACK NICE	1
12	6600030075	CONVEYOR SEAL	1
13	6600030019	CONVEYOR GALVANIZED METAL SHEET	1
14	6899940023	METAL SHEET + CONVEYOR SEAL-N2/G	1
15	6899940021	MOTOR PULLEY AND FAN ASSEMBLY-G	1
16	5100031286	KT ROUND LABEL D55 (ONLY EU VERSION)	1
17	6899940022BKT	COMPLETE ARM ASSEMBLY RAL9006-G	1
18	5100030247	WASHER OUT.D20 HOLE6.5 TH.3 GALVAN.	2
19	5800330605	SCREW UNI 5931 M6x22	2
20	6899940020	LED HANDLE+MOTOR+CONVEYOR 230V G	1
21	6899940055	LED HANDLE+MOTOR+CONVEYOR 115V G	

6899950002BKT - GEMINI 100 DUAL EDGE 230V/50Hz RAL 9006

6899950006BKT - GEMINI 100 DUAL EDGE 115V/60Hz RAL 9006



KUNZLE & TASIN
Via MARZABOTTO 63-20037-PADERNO DUGNANO (MI)
TEL.: 02/66040930 FAX: 02/66013445

GEMINI 100 Dual Edge

230-240V/50Hz - 115V/60Hz

KT-BONA
PAGE 1A/7

MAY 2022

1 LED HANDLE, MOTOR, CONVEYOR 230-240V/50Hz

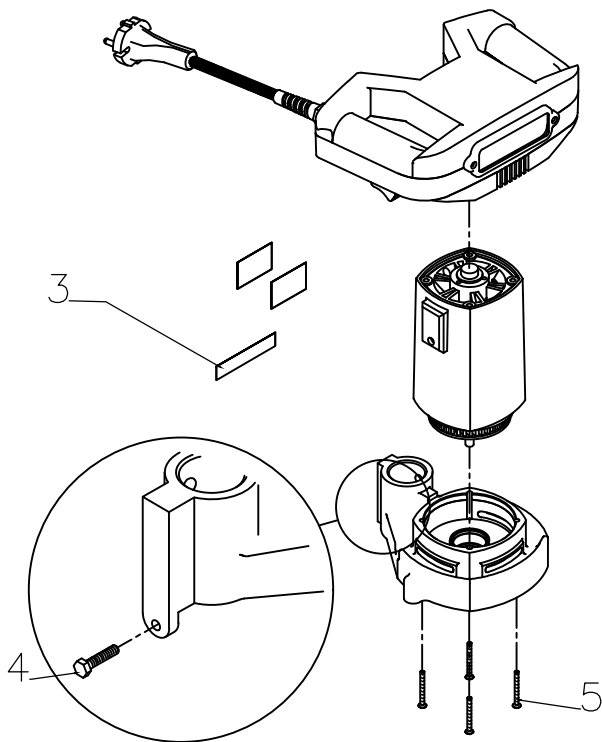

2 LED HANDLE, MOTOR, CONVEYOR 115V/60Hz

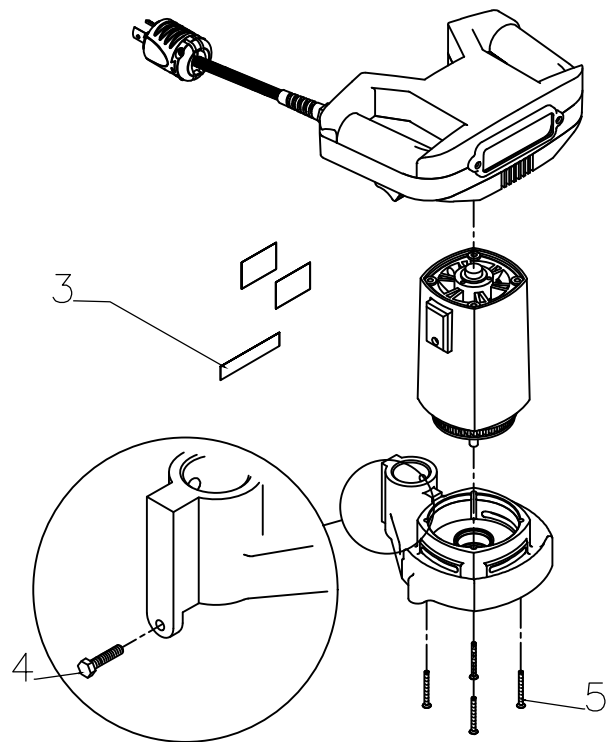

6
HANDLE SHELLS UL (pair only)

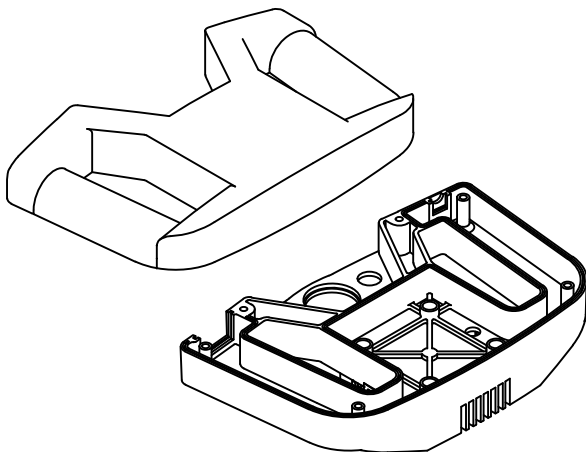

7
VELCRO BACKING DISC PAIR ø100mm

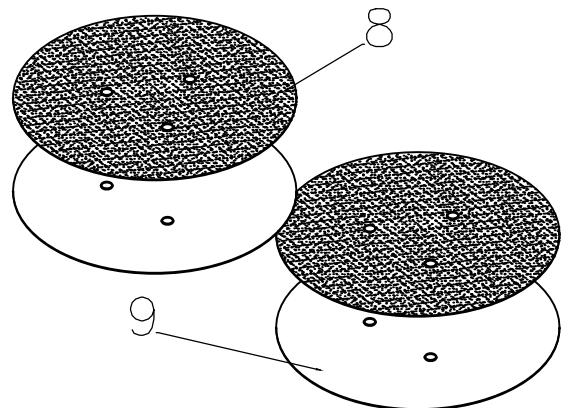

KUNZLE & TASIN
Via MARZABOTTO 63-20037-PADERNO DUGNANO (MI)
TEL.: 02/66040930 FAX: 02/66013445

GEMINI 100 Dual Edge

230-240V/50Hz - 115V/60Hz

KT-BONA

PAGE 2/7

MAY 2022

PARTS LIST

EL.	PART NUMBER	DESCRIPTION	N°
1	6899940020	LED HANDLE+MOTOR+CONVEYOR 230V G	1
2	6899940055	LED HANDLE+MOTOR+CONVEYOR 115V G	
3	ASO996104	WARNING LABEL 32X45-6 SYMBOLS	1
4	5800730603	SCREW M6X25 UNI 5739	1
5	5801030003	SCREW 4.8X45 CRPH SELF TAPP.UNI6954	4
6	6699940033	HANDLE SHELL PAIR-UL-N2/G (PAIR ONLY)	1
7	6899940230	VELCRO BACKING DISC PAIR-G	1
8	3000033000B	ADHESIVE VELCRO DISC-G100	2
9	6800030201	NEW BACKING DISC D.100-G	2

6899950002BKT - GEMINI 100 DUAL EDGE 230V/50Hz RAL 9006

6899950006BKT - GEMINI 100 DUAL EDGE 115V/60Hz RAL 9006



KUNZLE & TASIN
Via MARZABOTTO 63-20037-PADERNO DUGNANO (MI)
TEL.: 02/66040930 FAX: 02/66013445

GEMINI 100 Dual Edge

230-240V/50Hz - 115V/60Hz

KT-BONA

PAGE 2A/7

MAY 2022

COMPLETE HANDLE 230-240V / 50 Hz
(Page 3A)

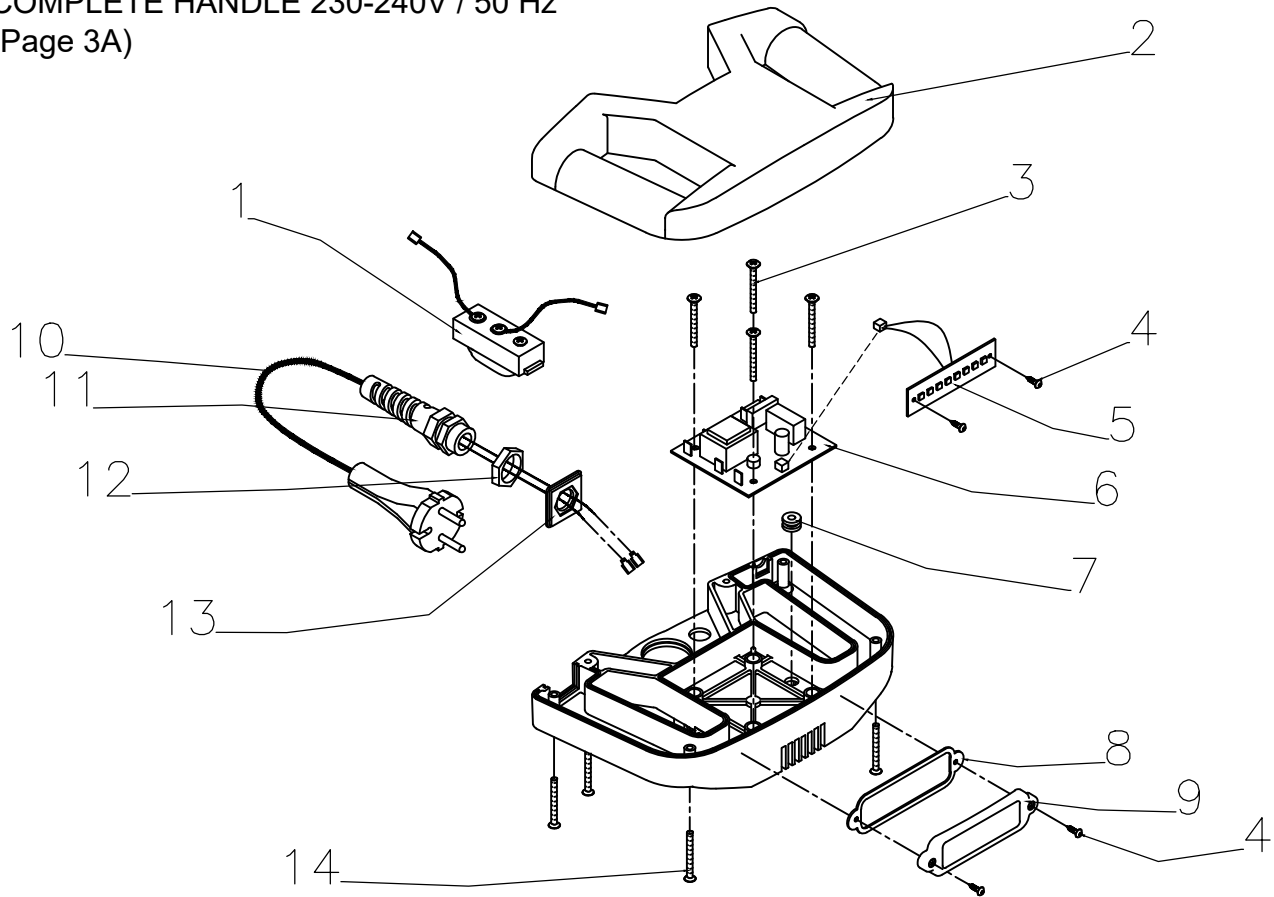

COMPLETE HANDLE 115V / 60Hz
(Page 3B)

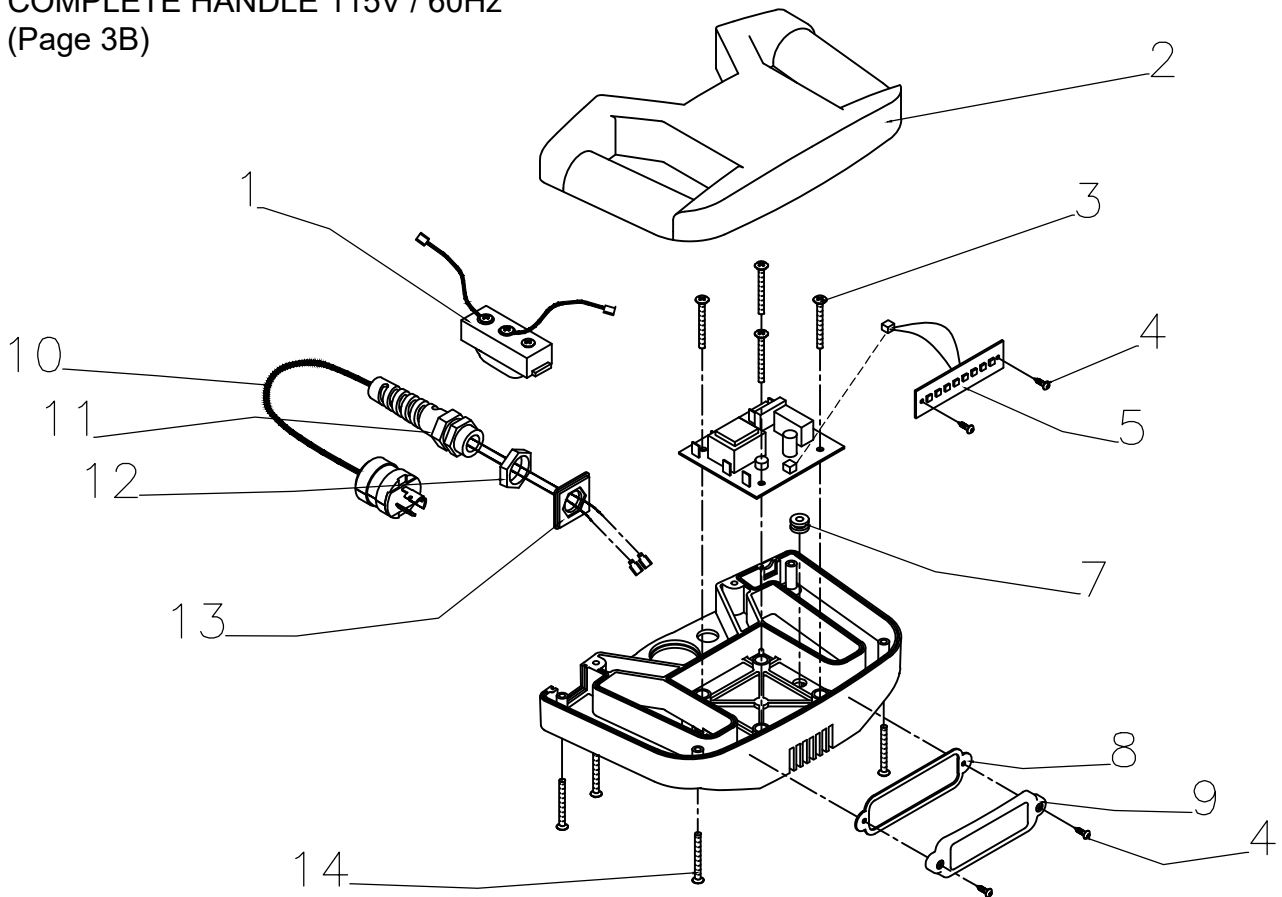

KUNZLE & TASIN
Via MARZABOTTO 63-20037-PADERNO DUGNANO (MI)
TEL.: 02/66040930 FAX: 02/66013445

GEMINI 100 Dual Edge

230-240V/50Hz - 115V/60Hz

KT-BONA

PAGE 3/7

MAY 2022

PARTS LIST 230-240V / 50 Hz

EL.	PART NUMBER	DESCRIPTION	N°
1	6899940038	NEW MICRO SWITCH ASSEMBLY N/G	1
2	6699940033	HANDLE SHELL PAIR-UL-N2/G	1
3	5801030020	SCREW 4.2X50 UNI6954 SELF-TAPPING	4
4	5801030009	SCREW 3.5X13 BLACK SELF-TAP.UNI6954	4
5	6800030055	UL WAFER LED	1
6	6800030060	LED A-TYPE PRINTED CIRCUIT BOARD	1
7	6600030031	STRAIN RELIEF 5523	1
8	6800030024	LED TRANSPARENT GUARD GASKET	1
9	6800030021	LED TRANSPARENT GUARD UL	1
10	6600030061	GREY CABLE H05VV-F2X1.5 L.230+SCHUK	1
11	5100030468	BLACK SPIRAL CABLE GLAND PG11	1
12	6600030029	BLACK RING NUT PG11 CH24	1
13	6600030027	CABLE GLAND COVER 230V/50HZ-N2	1
14	5801030001	SCREW 4.2x40 UNI6954 SELF-TAPPING	6

6899950002BKT - GEMINI 100 DUAL EDGE 230V/50Hz RAL 9006

6899950006BKT - GEMINI 100 DUAL EDGE 115V/60Hz RAL 9006



KUNZLE & TASIN
 Via MARZABOTTO 63-20037-PADERNO DUGNANO (MI)
 TEL.: 02/66040930 FAX: 02/66013445

GEMINI 100 Dual Edge

230-240V/50Hz - 115V/60Hz

KT-BONA

PAGE 3A/7

MAY 2022

PARTS LIST 115V / 60Hz

EL.	PART NUMBER	DESCRIPTION	N°
1	6899940038	NEW MICRO SWITCH ASSEMBLY N/G	1
2	6699940033	HANDLE SHELL PAIR-UL-N2/G	1
3	5801030020	SCREW 4.2X50 UNI6954 SELF-TAPPING	4
4	5801030009	SCREW 3.5X13 BLACK SELF-TAP.UNI6954	4
5	6800030055	UL WAFER LED	1
6	6800030061	LED 115V A-TYPE PCB (ROTOR LOCK)	1
7	6600030031	STRAIN RELIEF 5523	1
8	6800030024	LED TRANSPARENT GUARD GASKET	1
9	6800030021	LED TRANSPARENT GUARD UL	1
10	ASO901527	GREY CABLE+PLUG(UL)3X2.08 115/60HZ	1
11	5100030468	BLACK SPIRAL CABLE GLAND PG11	1
12	6600030029	BLACK RING NUT PG11 CH24	1
13	6600030027	CABLE GLAND COVER 230V/50HZ-N2	1
14	5801030001	SCREW 4.2x40 UNI6954 SELF-TAPPING	6

6899950002BKT - GEMINI 100 DUAL EDGE 230V/50Hz RAL 9006

6899950006BKT - GEMINI 100 DUAL EDGE 115V/60Hz RAL 9006



KUNZLE & TASIN
 Via MARZABOTTO 63-20037-PADERNO DUGNANO (MI)
 TEL.: 02/66040930 FAX: 02/66013445

GEMINI 100 Dual Edge

230-240V/50Hz - 115V/60Hz

KT-BONA

PAGE 3B/7

MAY 2022

1 MOTOR + CONVEYOR 230-240V/50Hz

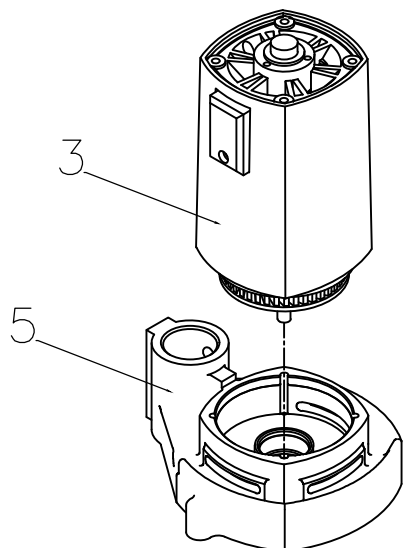

2 MOTOR + CONVEYOR 115V/60Hz

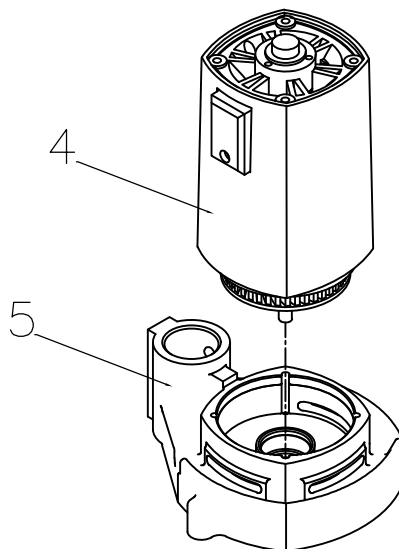

3
MOTOR 230-240V/50Hz

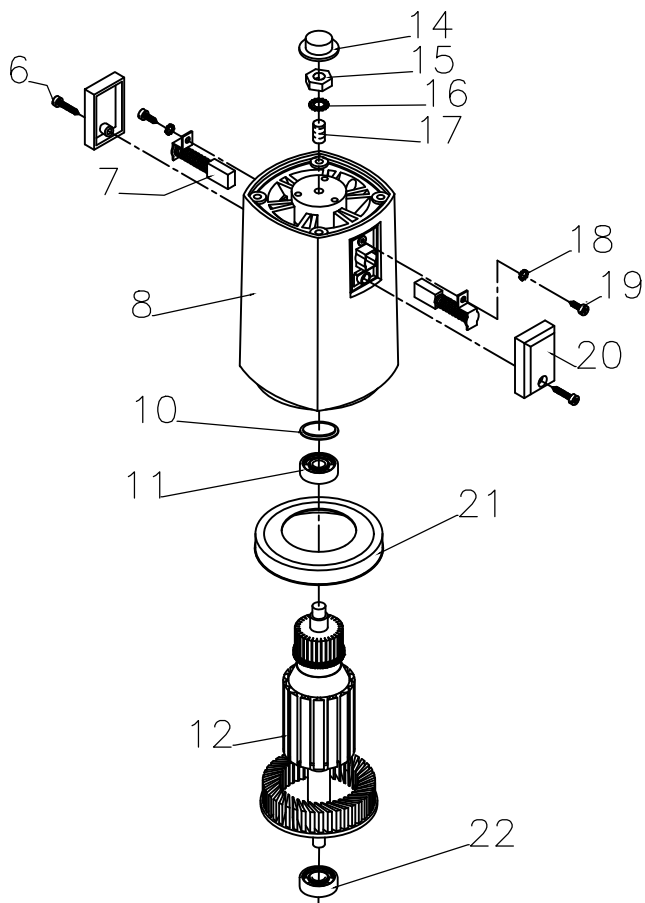

4
MOTOR 115V/60Hz

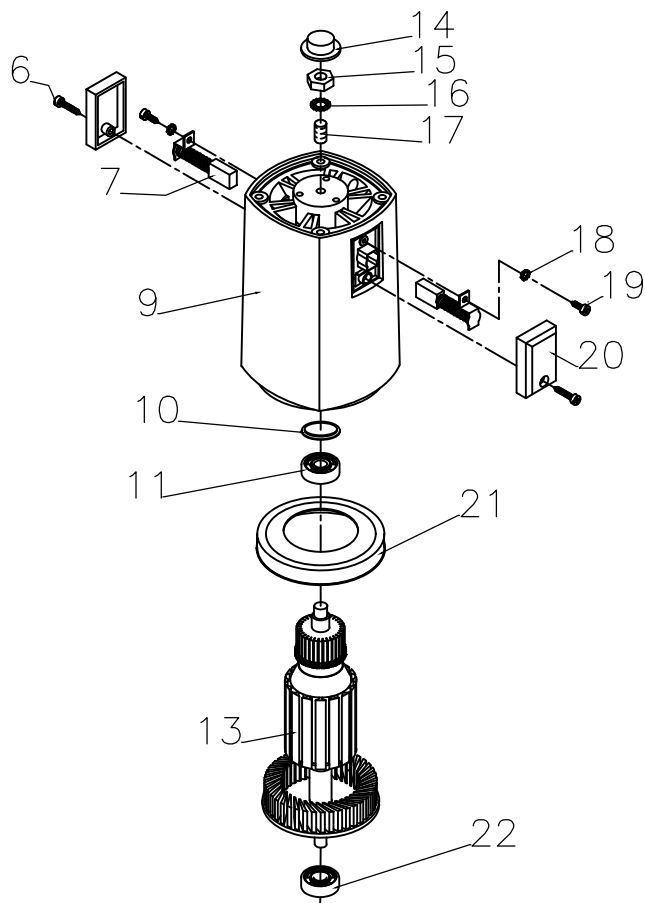

KUNZLE & TASIN
Via MARZABOTTO 63-20037-PADERNO DUGNANO (MI)
TEL.: 02/66040930 FAX: 02/66013445

GEMINI 100 Dual Edge

230-240V/50Hz - 115V/60Hz

KT-BONA

PAGE 4/7

MAY 2022

PARTS LIST

EL.	PART NUMBER	DESCRIPTION	N°
1	6899940019	MOTOR+CONVEYOR G100 230-240V/50Hz	1
2	6899940056	MOTOR+CONVEYOR 115V/60HZ G	
3	6600030030	COMPLETE MOTOR 230-240V/50HZ N2	1
4	6600030074	MOTOR 1150W 120V/60HZ UL N2	
5	6800040002NO	MACHINED BLACK CONVEYOR G	1
6	5800230404	SCREW M4X12 CROSS REC.PAN H.UNI7687	2
7	6600030039	CARBON BRUSH	2
8	6600030045	MOTOR FRAME 230/50+STATOR N2	1
9	6600030059	MOTOR FRAME 120/60+UL STATOR N2	
10	6600030126	THRUST BEARING PLATE	1
11	5804035003	BEARING 629 DD-MC3E-ROTOR N2	1
12	6600030036	ROTOR 230-240V/50HZ N	1
13	6600030024	ROTOR 120V/60HZ UL	
14	6600030041	NUT CAP	1
15	5801934001	M8 NUT UNI 5589	1
16	5802232004	SERRATED LOCK WASHER M8 UNI3704	1
17	5801530007	GRUB SCREW M8X14 UNI5927	1
18	5802232001	INT.SERR.LOCK WASHER M4 4.3 6798J	2
19	5800230405	SCREW M4X6 CROSS REC.PAN H.UNI7687	2
20	6600030038	COVER	2
21	6600030040	ROTOR FAN CAP	1
22	5804035004	BEARING 6201 C3 2RS	1



KUNZLE & TASIN
 Via MARZABOTTO 63-20037-PADERNO DUGNANO (MI)
 TEL.: 02/66040930 FAX: 02/66013445

GEMINI 100 Dual Edge

230-240V/50Hz - 115V/60Hz

KT-BONA

PAGE 4A/7

MAY 2022

1

COMPLETE CHASSIS RAL 9006

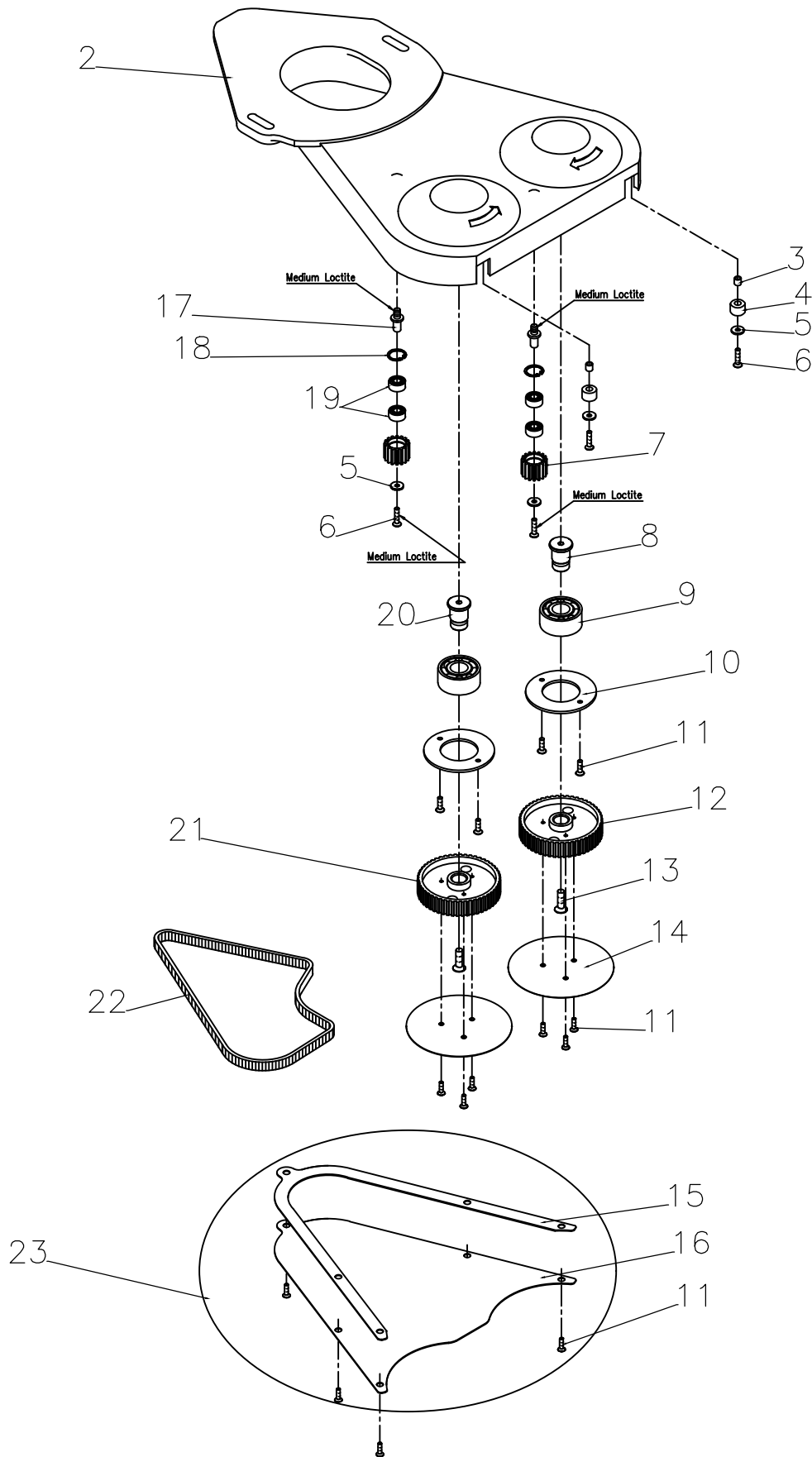

KUNZLE & TASIN
 Via MARZABOTTO 63-20037-PADERNO DUGNANO (MI)
 TEL.: 02/66040930 FAX: 02/66013445

GEMINI 1000 Dual Edge

230-240V/50Hz - 115V/60Hz

KT-BONA

PAGE 5/7

MAY 2022

PARTS LIST

EL.	PART NUMBER	DESCRIPTION	N°
1	6899940022BKT	COMPLETE ARM ASSEMBLY RAL9006-G	1
2	6800040003BKT	ARM RAL9006 - G100	1
3	6600030005	MACHINE BASE SPACER	2
4	6600030070	NEW WALL EDGE ROLLER D15.5-N2	2
5	5802230001	FLAT WASHER D4 UNI6592 GALVANIZED	4
6	5800230403	SCREW M4X16 UNI7687 GALVANIZED	2
7	6800030028	TIGHTENING PULLEY Z=16-G	2
8	6600030002	RIGHT-END THREAD PIN N2	1
9	5804033003	BEARING 3203 A 2RS S	2
10	6800030104	BEARING BLIND FLANGE-G	2
11	5800530402	SCREW M4X12 CRFH UNI7688 DIN965 GAL	17
12	6800030102	RIGHT 48-TEETH PULLEY-G100	1
13	5800630801	SCREW M8x20 UNI5933 GALVANIZED	2
14	6899940230	VELCRO BACKING DISC PAIR-G (PAIR ONLY)	1
15	6800030032	DRIVE BELT METAL SHEET SEAL-G	1
16	6800030014	LOCK METAL SHEET	1
17	6800030013	DRIVE BELT TIGHTENING PIN G	2
18	5803031015	SNAP RING I 19	2
19	5804032019	BEARING 607-2RS 7X19X6	4
20	6800030035	LEFT-HAND THREAD PIN G	1
21	6800030103	LEFT 48-TEETH PULLEY-G100	1
22	6800030042	S.MU.SPE.HD DU.5M LP=600 DRIVE BELT	1
23	6899940026	DRIVE BELT METAL SHEET+SEAL-G	1



KUNZLE & TASIN
 Via MARZABOTTO 63-20037-PADERNO DUGNANO (MI)
 TEL.: 02/66040930 FAX: 02/66013445

GEMINI 1000 Dual Edge

230-240V/50Hz - 115V/60Hz

KT-BONA

PAGE 5A/7

MAY 2022

1

10MT POWER CABLE SCHUKO/SCHUKO

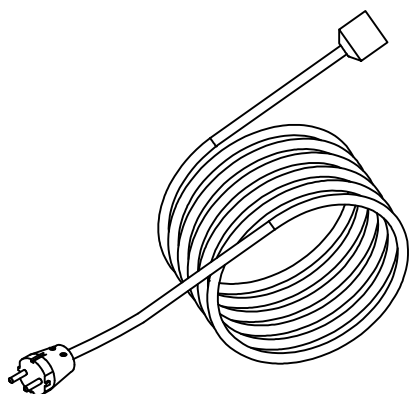

2

PLUG ADAPTER 13A UK
EXTRA ITEM

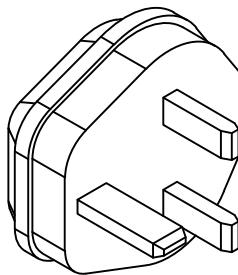

3

10MT POWER CABLE 115V/60HZ (USA)

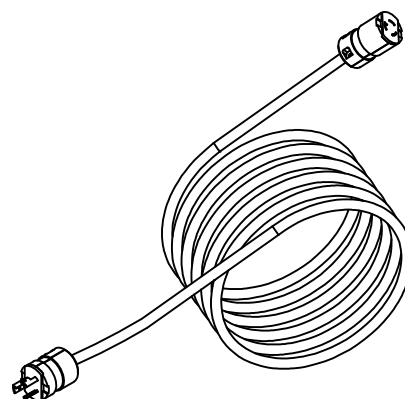

4

FABRIC DUST BAG (EU)

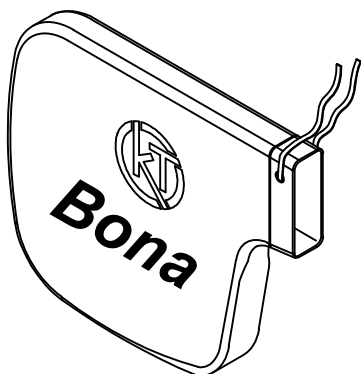

5

FABRIC DUST BAG (USA)

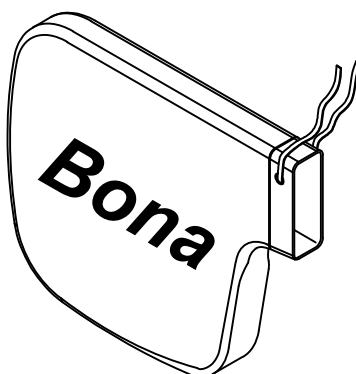

6

CLAMP 1,5"
ONLY FOR USA VERSION

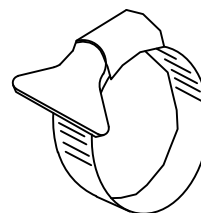

7

FLARED END SUCTION PIPE $\varnothing 35/\varnothing 38$
ONLY FOR USA VERSION

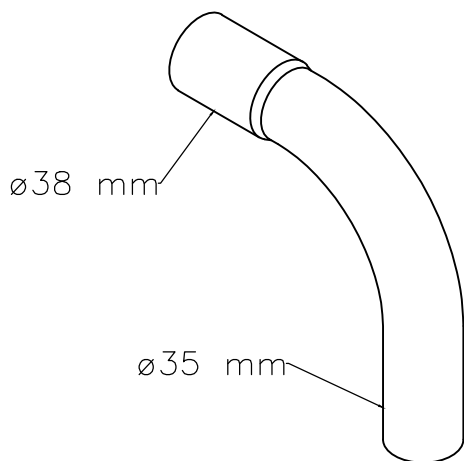

8

TOOL BAG GEMINI 100

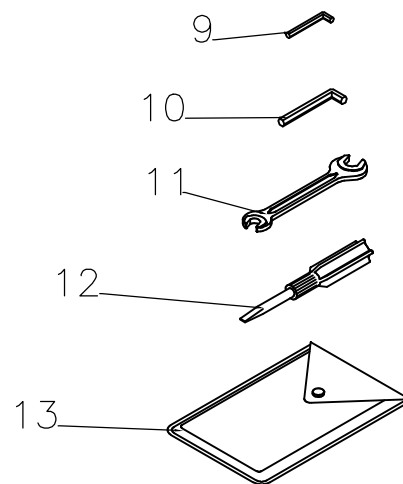

KUNZLE & TASIN
Via MARZABOTTO 63-20037-PADERNO DUGNANO (MI)
TEL. 02/66040930 FAX 02/66013445

GEMINI 100 Dual Edge

230-240V/50Hz - 115V/60Hz

KT-BONA

PAGE 6/6

MAY 2022

PARTS LIST

EL.	PART NUMBER	DESCRIPTION	N°
1	ASO904023	EXTENSION LEAD-10M 3X2.5 SCHUKO/SCH	1
2	5100031283	POWER PLUG ADAPTER 13A UK	1
3	ASO904025	CABLE EXTENSION 1-PH 3XAWG14 USA	1
4	ASO992003	DUST BAG-EU EDGE	1
5	ASO992002	DUST BAG-USA EDGE	1
6	ASO539050	HOSE CLAMP 1.5"+HANDWHEEL	1
7	6600030144	FLARED END SUCTION PIPE D35/38-N/G	1
8	6899940050	TOOL BAG-G100	1
9	5100031036	ALLEN KEY N.3 GALVANIZED	1
10	0200030299	ALLEN KEY N.5 GALVANIZED	1
11	5100031021	SPANNER 10/13 GALVANIZED	1
12	5100030145	DOUBLE ENDED SCREWDRIVER	1
13	5100030144	PVC SMALL BAG	1



KUNZLE & TASIN
 Via MARZABOTTO 63-20037-PADERNO DUGNANO (MI)
 TEL.: 02/66040930 FAX: 02/66013445

GEMINI 1000 Dual Edge

230-240V/50Hz - 115V/60Hz

KT-BONA

PAGE 6A/7

MAY 2022

1

NEW TRANSMISSIO.CONVERSION KIT-G100

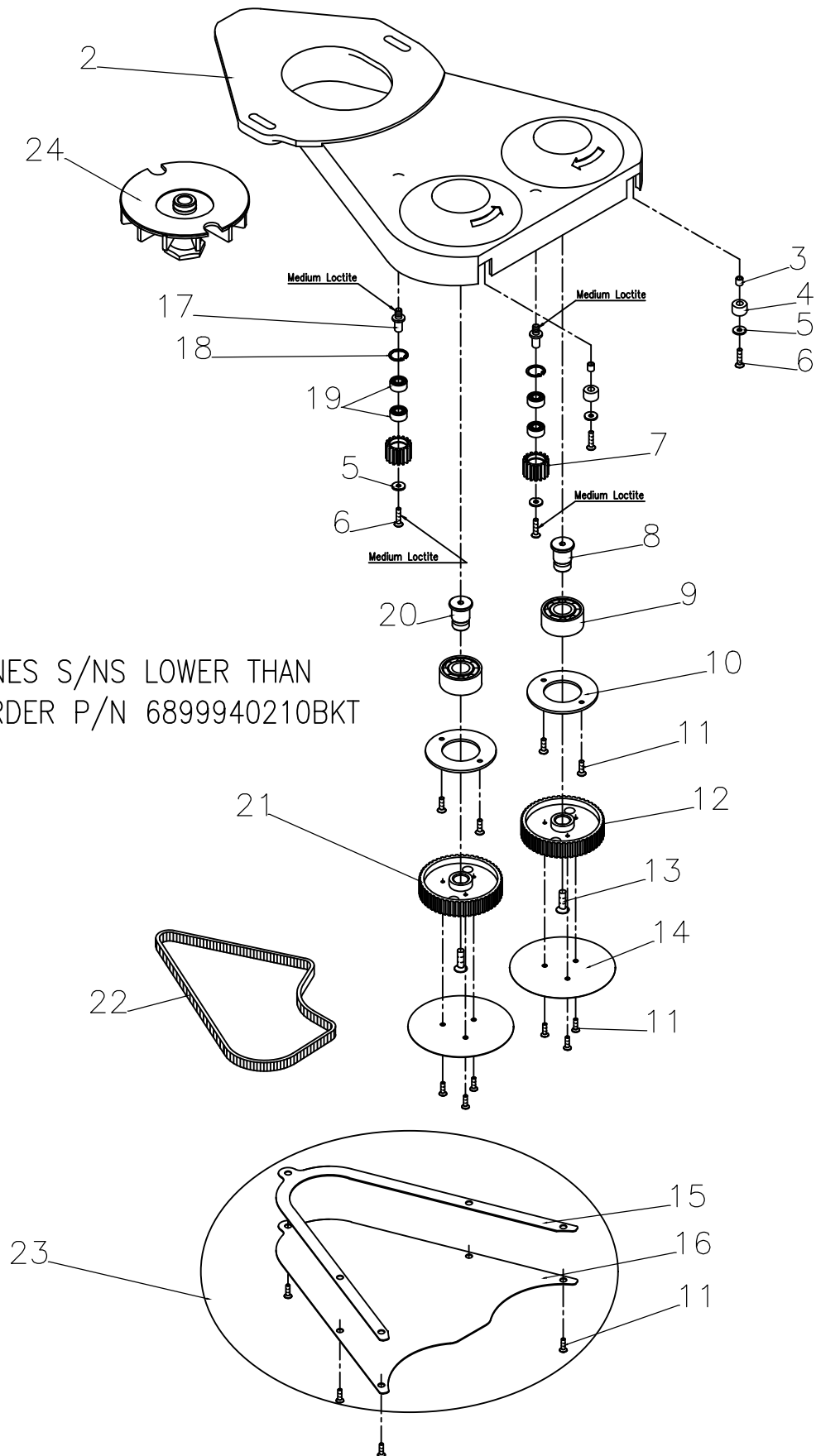

FOR MACHINES S/NS LOWER THAN
GE2204201, ORDER P/N 6899940210BKT



KUNZLE & TASIN
Via MARZABOTTO 63-20037-PADERNO DUGNANO (MI)
TEL.: 02/66040930 FAX: 02/66013445

GEMINI 100 Dual Edge

230-240V/50Hz - 115V/60Hz

KT-BONA

PAGE 7/7

MAY 2022

PARTS LIST

EL.	PART NUMBER	DESCRIPTION	N°
1	6899940210BKT	NEW TRANSMISSIO.CONVERSION KIT-G100	1
2	6800040003BKT	ARM RAL9006 - G100	1
3	6600030005	MACHINE BASE SPACER	2
4	6600030070	NEW WALL EDGE ROLLER D15.5-N2	2
5	5802230001	FLAT WASHER D4 UNI6592 GALVANIZED	4
6	5800230403	SCREW M4X16 UNI7687 GALVANIZED	2
7	6800030028	TIGHTENING PULLEY Z=16-G	2
8	6600030002	RIGHT-END THREAD PIN N2	1
9	5804033003	BEARING 3203 A 2RS S	2
10	6800030104	BEARING BLIND FLANGE-G	2
11	5800530402	SCREW M4X12 CRFH UNI7688 DIN965 GAL	17
12	6800030102	RIGHT 48-TEETH PULLEY-G100	1
13	5800630801	SCREW M8x20 UNI5933 GALVANIZED	2
14	6899940230	VELCRO BACKING DISC PAIR-G (PAIR ONLY)	1
15	6800030032	DRIVE BELT METAL SHEET SEAL-G	1
16	6800030014	LOCK METAL SHEET	1
17	6800030013	DRIVE BELT TIGHTENING PIN G	2
18	5803031015	SNAP RING I 19	2
19	5804032019	BEARING 607-2RS 7X19X6	4
20	6800030035	LEFT-HAND THREAD PIN G	1
21	6800030103	LEFT 48-TEETH PULLEY-G100	1
22	6800030042	S.MU.SPE.HD DU.5M LP=600 DRIVE BELT	1
23	6899940026	DRIVE BELT METAL SHEET+SEAL-G	1
24	6899940021	MOTOR PULLEY AND FAN ASSEMBLY-G	1



KUNZLE & TASIN
 Via MARZABOTTO 63-20037-PADERNO DUGNANO (MI)
 TEL.: 02/66040930 FAX: 02/66013445

GEMINI 100 Dual Edge

230-240V/50Hz - 115V/60Hz

KT-BONA

PAGE 7A/7

MAY 2022