

K&T STANDARD COLOUR: HAMMERED BLUE (ANY OTHER RAL COLOUR AVAILABLE ON DEMAND AND SUBJECT TO A MINIMUM REQUESTED QUANTITY)

24.999.5.0000 - PEGASUS 230V/50Hz
 24.999.5.0000SW - PEGASUS 230V/50Hz SPHERICAL WHEEL
 24.999.5.0001 - PEGASUS 115V/60Hz
 24.999.5.0002 - PEGASUS 240V/50Hz

24.999.5.0003 - PEGASUS 220V/60Hz
 24.999.5.0004 - PEGASUS 240V/50Hz UK
 24.999.5.0004SW - PEGASUS 240V/50Hz UK SPHERICAL WHEEL
 24.999.5.0005 - PEGASUS 115V/50Hz



KUNZLE & TASIN
 Via CAJKOVSKIJ 14-20092-CINISELLO BALSAMO (MI)
 TEL. 02/66040930 FAX 02/66013445

PEGASUS
 230V/50Hz - 240V/50Hz - 220V/60Hz
 115V/50Hz - 115V/60Hz

COMMERCIALE

PAGE 1/6

MAY 2015

52.999.4.0506

STATOR 230V/50Hz

52.999.4.0507

STATOR 115V/60Hz

52.999.4.0508

STATOR 240V/50Hz

52.999.4.0509

STATOR 220V/60Hz

52.999.4.0510

STATOR 115V/50Hz

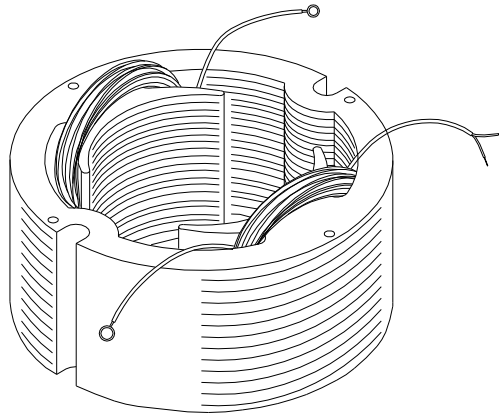

52.999.4.0224

COMPLETE ROTOR 115V/50Hz

52.999.4.0225

COMPLETE ROTOR 230V/50Hz

52.999.4.0226

COMPLETE ROTOR 115V/60Hz

52.999.4.0227

COMPLETE ROTOR 240V/50Hz

52.999.4.0228

COMPLETE ROTOR 220V/60Hz

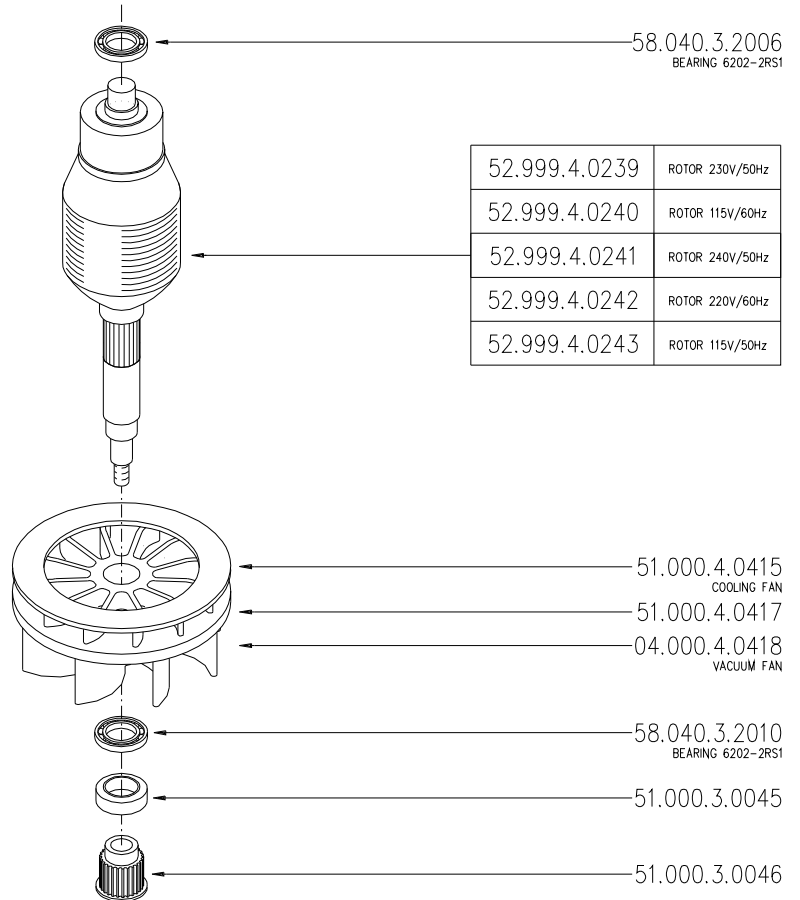

52.999.4.0239	ROTOR 230V/50Hz
52.999.4.0240	ROTOR 115V/60Hz
52.999.4.0241	ROTOR 240V/50Hz
52.999.4.0242	ROTOR 220V/60Hz
52.999.4.0243	ROTOR 115V/50Hz



KUNZLE & TASIN
Via CAJKOVSKIJ 14-20092-CINISELLO BALSAMO (MI)
TEL. 02/66040930 FAX 02/66013445

PEGASUS
230V/50Hz - 240V/50Hz - 220V/60Hz
115V/50Hz - 115V/60Hz

COMMERCIALE

PAGE 2/6

MAY 2015

58.003.3.0605
N°4 SCREW (VTCEI) M6x22

58.022.3.2003
N°4 NOTCHED WASHER ø6

51.000.3.0083

25.000.3.0009
CLOSURE STUD M8x35
58.022.3.0004
WASHER ø8,4xø16x1,6

52.999.4.0214
52.999.4.0213KT

24.000.3.0031

58.005.3.0402
N°7 SCREW (VTSIC) M4x12

24.999.4.0003

58.005.3.0402
N°9 SCREW (VTSIC) M4x12

52.999.4.0546GA

51.000.3.0050

58.007.3.0803
SCREW (VTE) M8x25

51.000.4.0034KT

51.000.3.0001

51.000.3.0029

51.000.3.0013

24.000.3.0010

24.999.4.0001
COMPLETE PULLEY ASSEMBLY

58.006.3.0604
N°3 SCREW (VTSEI) M6x18

58.030.3.0003
RING 15E

58.040.3.3002
3202 2RS BEARING

24.999.4.0001



KUNZLE & TASIN
Via CAJKOVSKIJ 14-20092-CINISELLO BALSAMO (MI)
TEL. 02/66040930 FAX 02/66013445

PEGASUS

COMMERCIALE

PAGE 3/6

MAY 2015

52.999.4.0213KT

COMPLETE "SPHERICAL WHEEL" GROUP

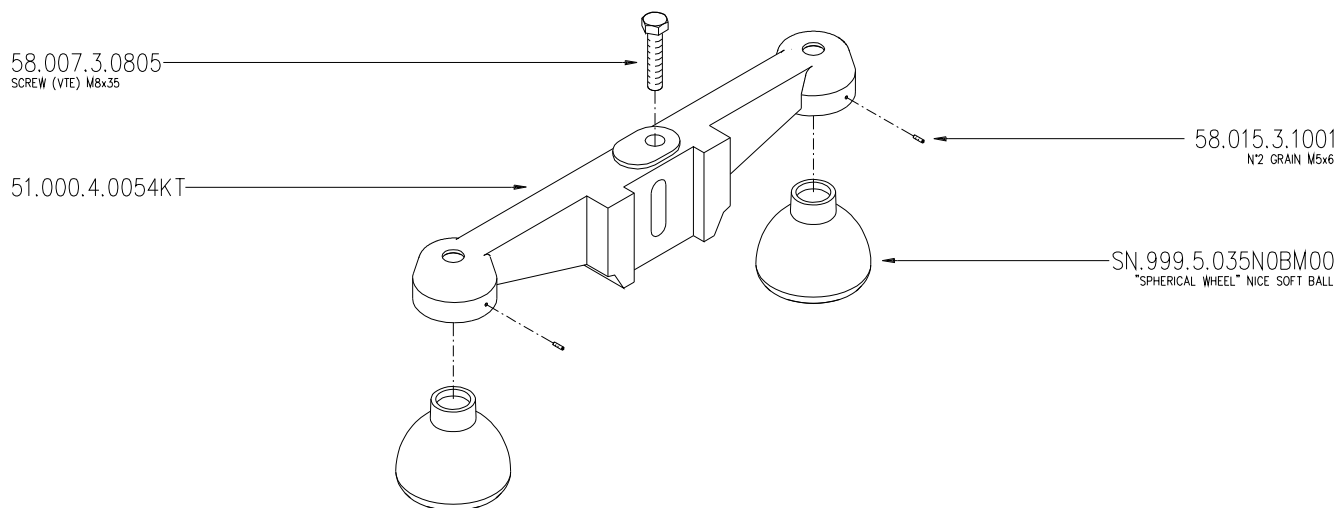

52.999.4.0214

WHEELS COMPLETE GROUP

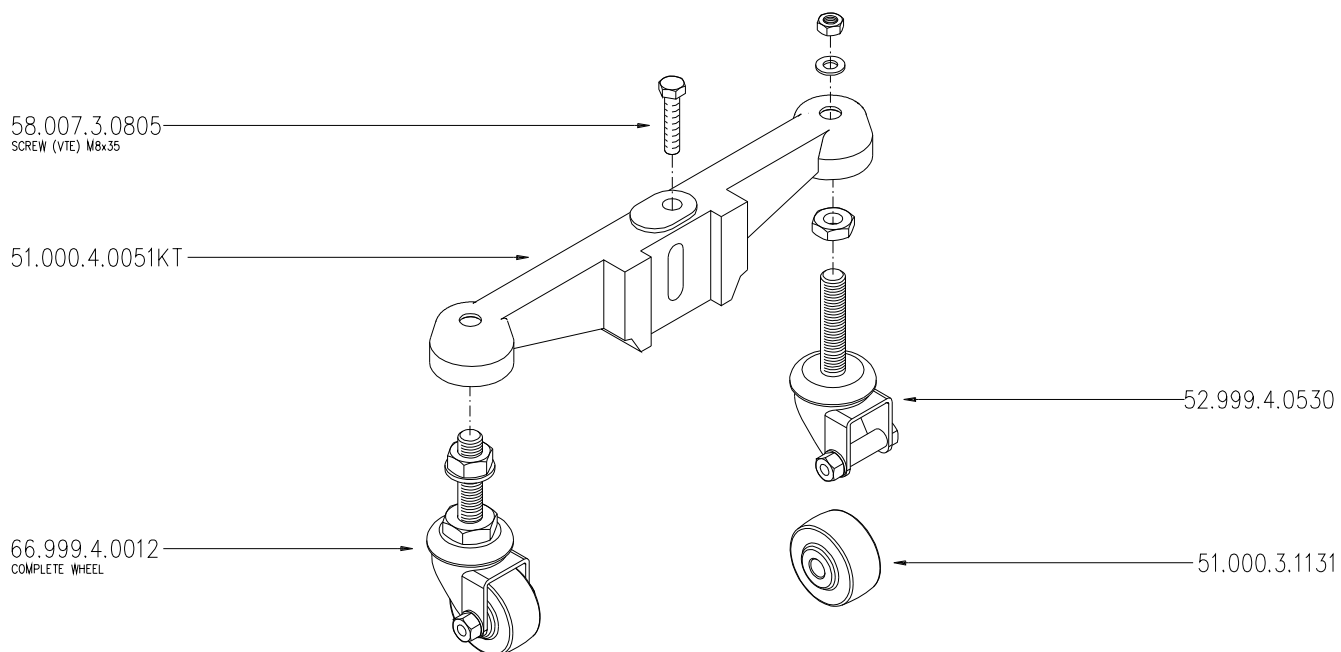

KUNZLE & TASIN
Via CAJKOVSKIJ 14-20092-CINISELLO BALSAMO (MI)
TEL. 02/66040930 FAX 02/66013445

PEGASUS

COMMERCIALE

PAGE 4/6

MAY 2015

24.000.3.0063

2 PAPER DUST BAGS BLISTER

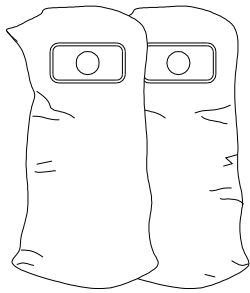

EXTRA ITEM

52.999.4.0576

COMPLETE PAPER BAG HOLDER

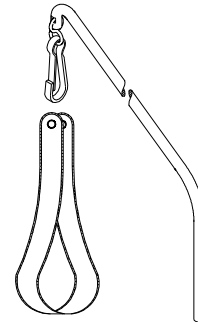

EXTRA ITEM

52.999.4.0580

FABRIC DUST BAG WITH LOGO

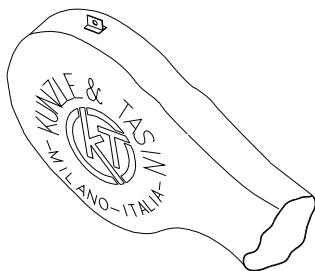

52.999.4.0575

BAG HOLDER

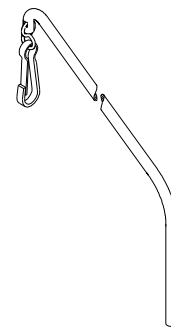

04.999.4.0570

COMPLETE COMPASS

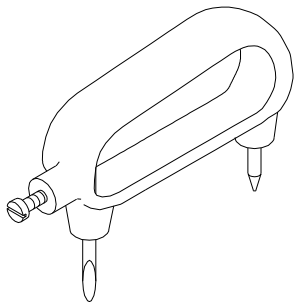

24.999.4.0004

FRONT HANDGRIP

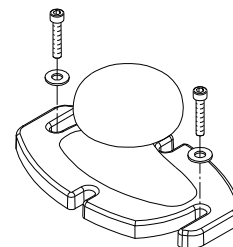

EXTRA ITEM

52.999.4.0056

EXTRA HANDGRIP

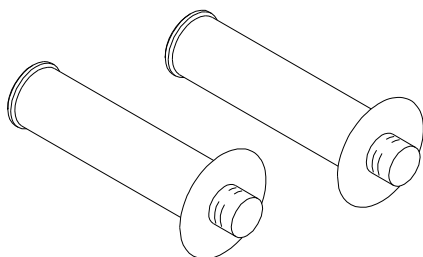

51.000.3.1283

PLUG ADAPTOR 13A UK

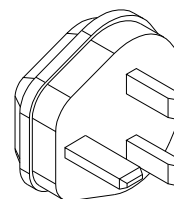

KUNZLE & TASIN

Via CAJKOVSKIJ 14-20092-CINISELLO BALSAMO (MI)
TEL. 02/66040930 FAX 02/66013445

PEGASUS

COMMERCIALE

PAGE 5/6

MAY 2015

29.000.3.0135

7 MT POWER CABLE (SOCKET SCHUKO+PLUG USA)

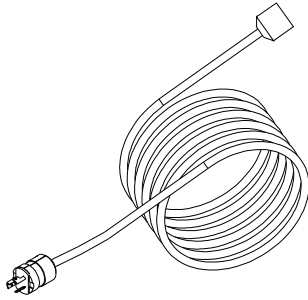

29.000.3.0115

7 MT POWER CABLE (SOCKET AND PLUG SCHUKO)

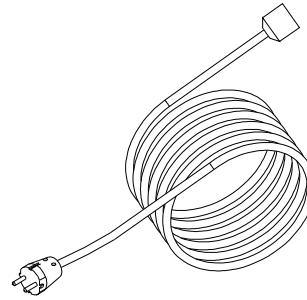

67.999.3.0019

10 MT POWER CABLE (SOCKET AND PLUG USA)

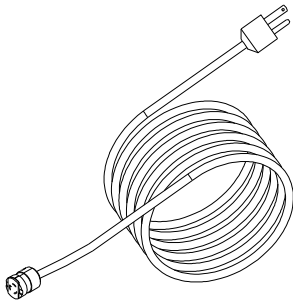

52.999.3.0001

15 MT POWER CABLE (SOCKET AND PLUG USA)

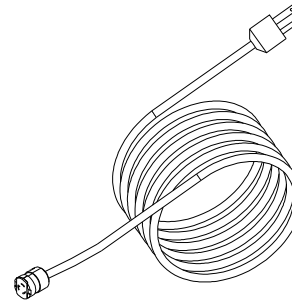

29.000.3.0078

CABLE 200 MM + PLUG SCHUKO

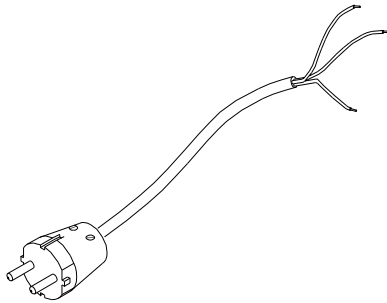

52.999.4.0581

TOOLBAG

51.000.3.0144
PVC BAG

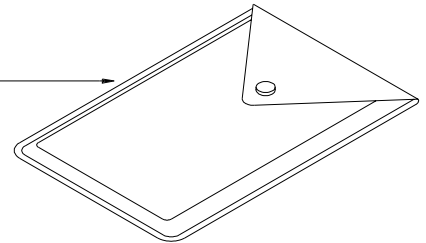

51.000.3.0149
BOX SPANNER 13/13

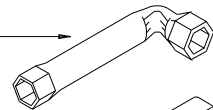

51.000.3.0472
PUNCH

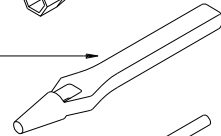

51.000.3.0148
ROD

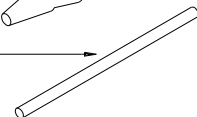

02.000.3.0299
ALLEN WRENCH 5

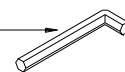

51.000.3.1036
ALLEN WRENCH 3



52.999.4.1191

CABLE 200 MM + PLUG USA

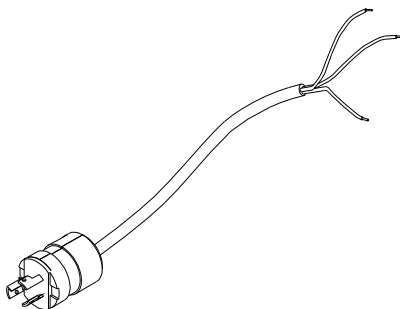

KUNZLE & TASIN
Via CAJKOVSKIJ 14-20092-CINISELLO BALSAMO (MI)
TEL. 02/66040930 FAX 02/66013445

PEGASUS

COMMERCIALE

PAGE 6/6

MAY 2015