

**K&T STANDARD COLOUR: GREY RAL 9006 (ANY OTHER RAL COLOUR AVAILABLE ON DEMAND AND SUBJECT TO A MINIMUM REQUESTED QUANTITY)**

25.999.5.0000GKT - VEGA 230V/50Hz GREY 9006  
25.999.5.0000SWGKT - VEGA 230V/50Hz SPHERICAL WHEEL GREY 9006



**KUNZLE & TASIN**  
Via CAJKOVSKIJ 14-20092-CINISELLO BALSAMO (MI)  
TEL. 02/66040930 FAX 02/66013445

**VEGA**  
230V/50Hz

COMMERCIALE

PAGE 1/6

MAY 2016

# 52.999.4.0506

STATOR 230V/50Hz

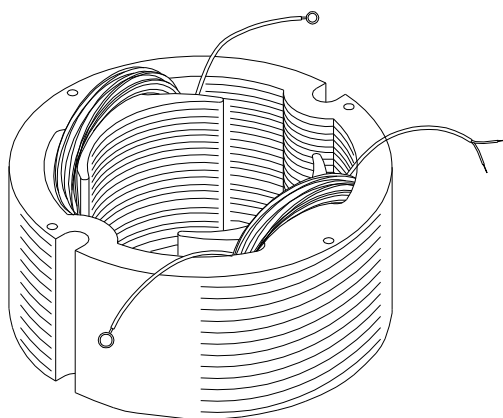

# 52.999.4.0225

COMPLETE ROTOR 230V/50Hz

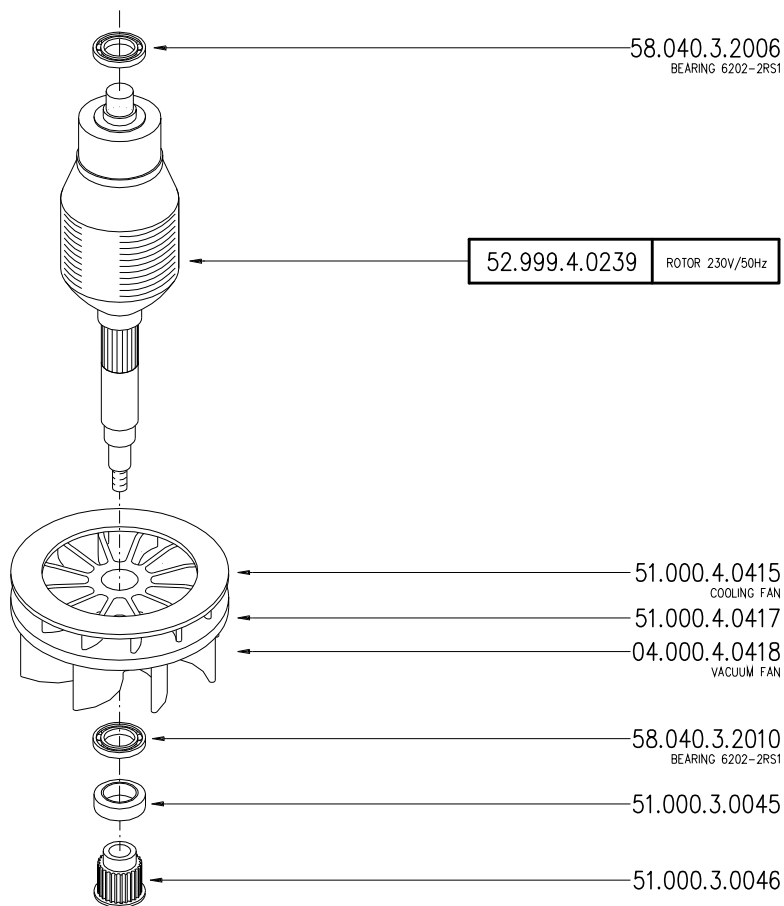

**KUNZLE & TASIN**  
Via CAJKOVSKIJ 14-20092-CINISELLO BALSAMO (MI)  
TEL. 02/66040930 FAX 02/66013445

**VEGA**  
230V/50Hz

COMMERCIALE

PAGE 2/6

MAY 2016

58.003.3.0605  
N°4 SCREW (VTCEI) M6x22

58.022.3.2003  
N°4 NOTCHED WASHER ø6

51.000.3.0083

25.000.3.0009  
CLOSURE STUD M8x35  
58.022.3.0004  
WASHER ø8,4xø16x1,6

52.999.4.0214BKT  
52.999.4.0213BKT

25.000.3.0005

25.999.4.0007

58.005.3.0402  
N°6 SCREW (VTSEI) M4x12

52.999.4.0546GA

51.000.3.0050

58.007.3.0803  
SCREW (VTE) M8x25

51.000.4.0034BKT

51.000.3.0029

51.000.3.0001

51.000.3.0013

25.000.3.0007

58.005.3.0402  
N°6 SCREW (VTSEI) M4x12

25.999.4.0003

58.006.3.0604  
N°3 SCREW (VTSEI) M6x18

58.030.3.0003  
SECTOR 15°

58.040.3.3002  
3202 2RS BEARING

25.999.4.0003



**KUNZLE & TASIN**  
Via CAJKOVSKIJ 14-20092-CINISELLO BALSAMO (MI)  
TEL. 02/66040930 FAX 02/66013445

**VEGA**

COMMERCIALE

PAGE 3/6

MAY 2016

# 52.999.4.0213BKT

COMPLETE "SPHERICAL WHEEL" GROUP RAL 9006

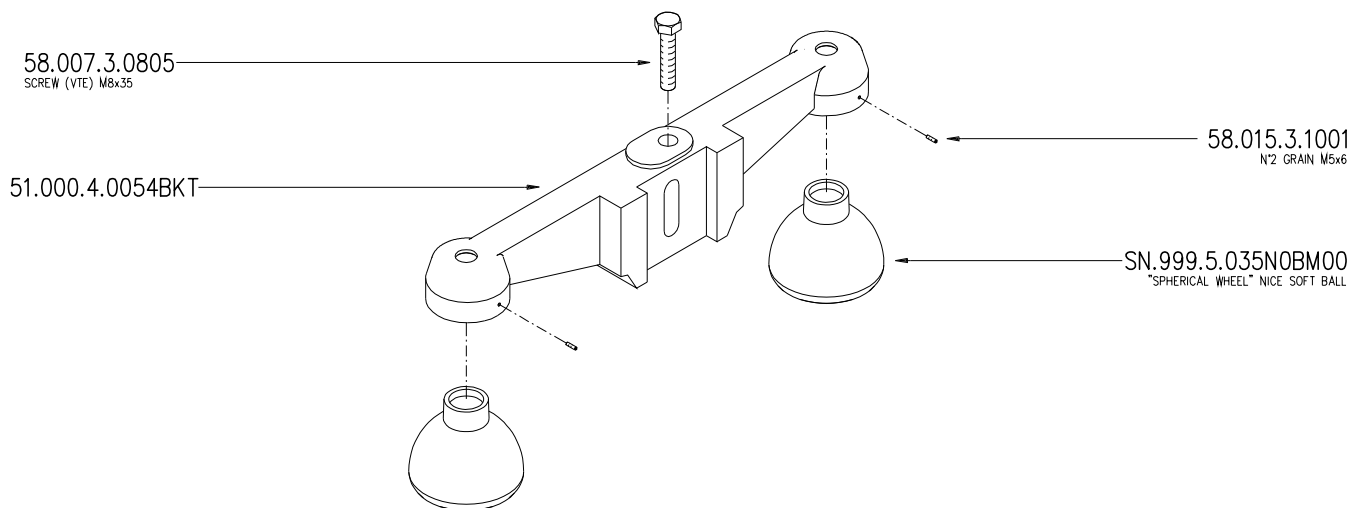

# 52.999.4.0214BKT

WHEELS COMPLETE GROUP RAL 9006

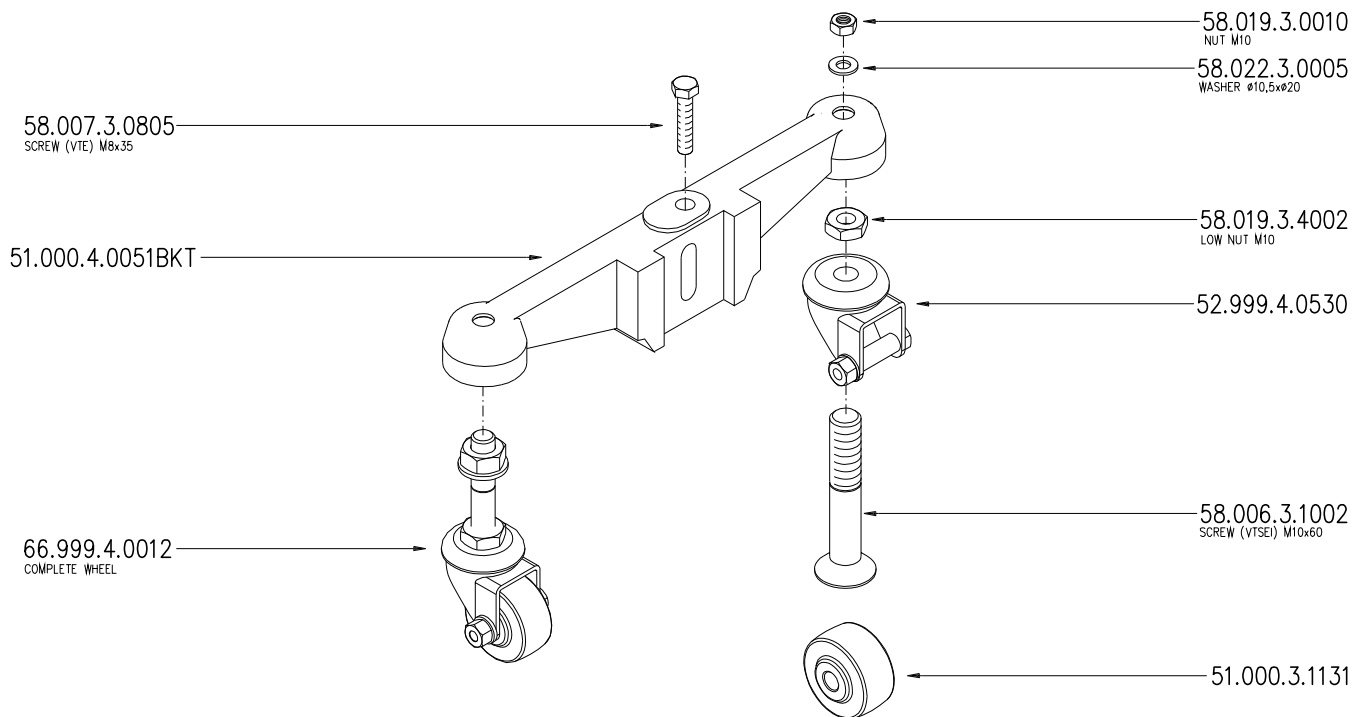

**KUNZLE & TASIN**  
Via CAJKOVSKIJ 14-20092-CINISELLO BALSAMO (MI)  
TEL. 02/66040930 FAX 02/66013445

**VEGA**

COMMERCIALE

PAGE 4/6

MAY 2016

24.000.3.0063

2 PAPER DUST BAGS BLISTER

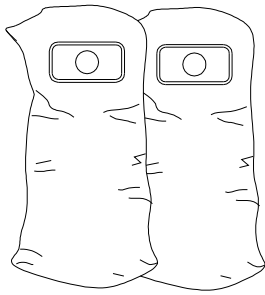

52.999.4.0576

COMPLETE PAPER BAG HOLDER

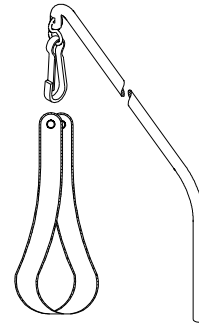

52.999.4.0580

SACCO SERIGRAFATO

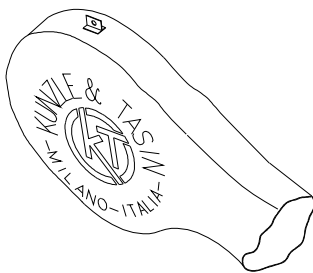

52.000.2.0468

SACCO TELA NEUTRO

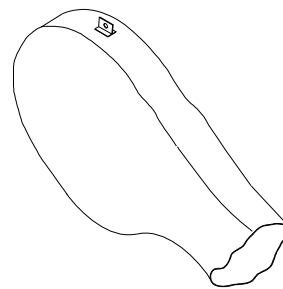

04.999.4.0570

COMPLETE COMPASS

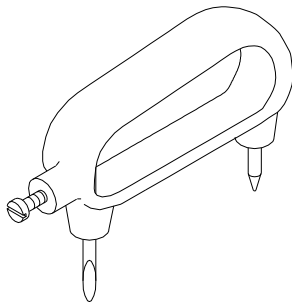

52.999.4.0575

BAG HOLDER

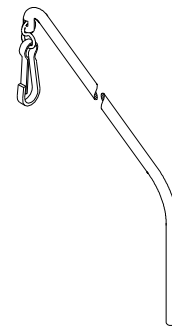

24.999.4.0005

ADAPTER FOR EXTERNAL VACUUM UNIT

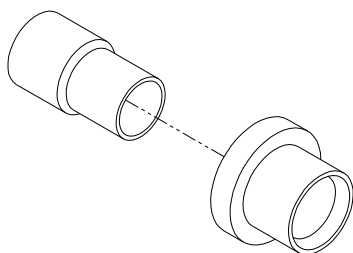

51.000.3.1283

PLUG ADAPTOR 13A UK

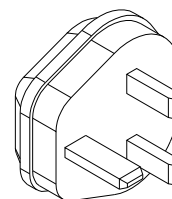

**KUNZLE & TASIN**

Via CAJKOVSKIJ 14-20092-CINISELLO BALSAMO (MI)  
TEL. 02/66040930 FAX 02/66013445

**VEGA**

COMMERCIALE

PAGE 5/6

MAY 2016

29.000.3.0135

7 MT POWER CABLE (SOCKET SCHUKO+PLUG USA)

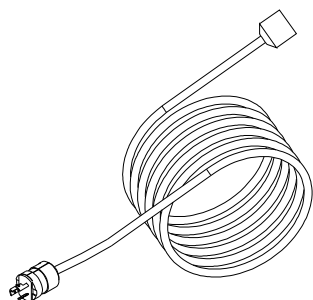

29.000.3.0115

7 MT POWER CABLE (SOCKET AND PLUG SCHUKO)

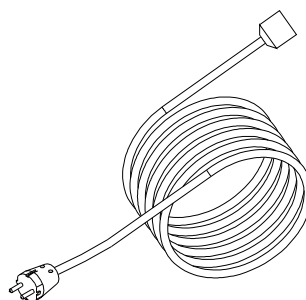

67.999.3.0019

10 MT POWER CABLE (SOCKET AND PLUG USA)

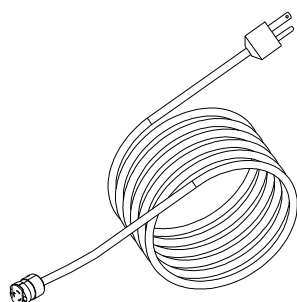

52.999.3.0001

15 MT POWER CABLE (SOCKET AND PLUG USA)

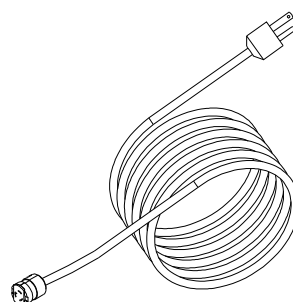

29.000.3.0078

CABLE 200 MM + PLUG SCHUKO

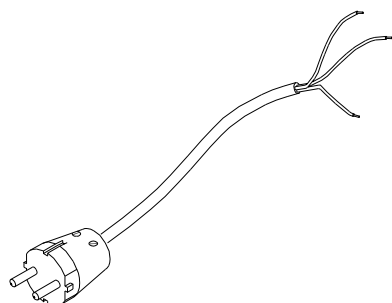

52.999.4.0581

TOOLBAG

51.000.3.0144  
PVC BAG

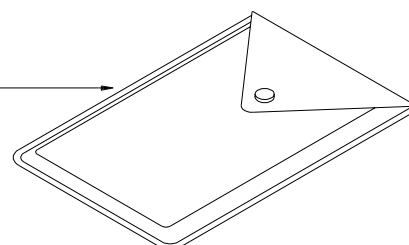

51.000.3.0149  
BOX SPANNER 13/13

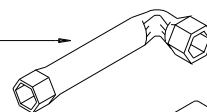

51.000.3.0472  
PUNCH

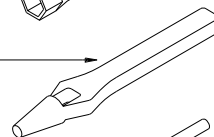

51.000.3.0148  
ROD

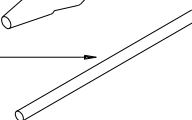

02.000.3.0299  
ALLEN WRENCH 5

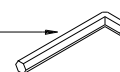

51.000.3.1036  
ALLEN WRENCH 3



52.999.4.1191

CABLE 200 MM + PLUG USA

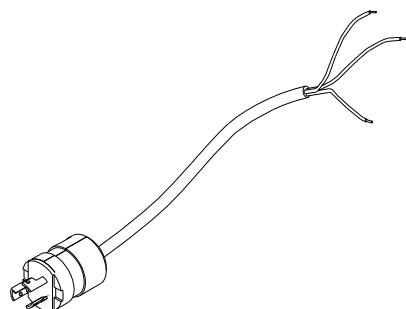

KUNZLE & TASIN

Via CAJKOVSKIJ 14-20092-CINISELLO BALSAMO (MI)  
TEL. 02/66040930 FAX 02/66013445

**VEGA**

COMMERCIALE

PAGE 6/6

MAY 2016