

MOUNTING INSTRUCTION:

- Aim the template in the upper hole (1) and screw it in the existing hole of the machine.
- Put it straight vertical and mark the position of the hole n°2 on the machine.
- Unscrew the template from the machine
- Drill a hole on the machine with a diameter of 5mm on the marked position
- Repeat the procedure on the other side of the machine
- Install the modification kit like showed below

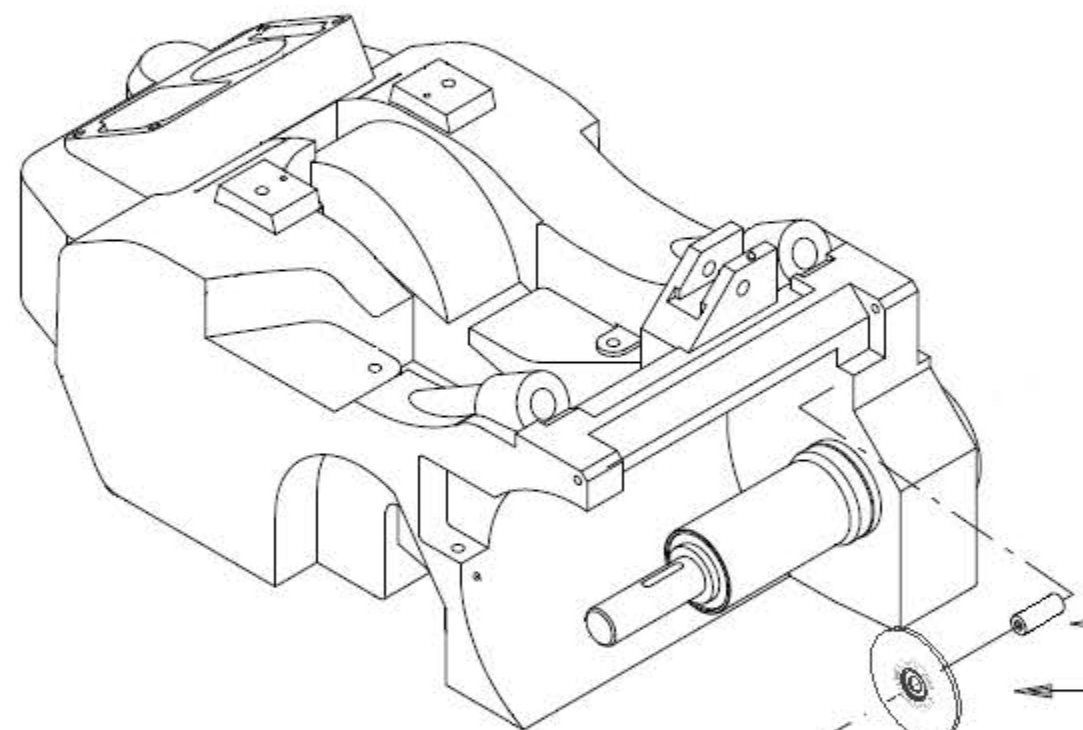

- 6900030023 - 6X10X12 SPACER
- 6900030024 + ASO910626 - PAPER GUARD ROLLER CAPRICORN + 626-2RSH BEARING
- 5800030630 - M6X30 UL.LO.HE.TO.CA.HE.GAL.SCREW

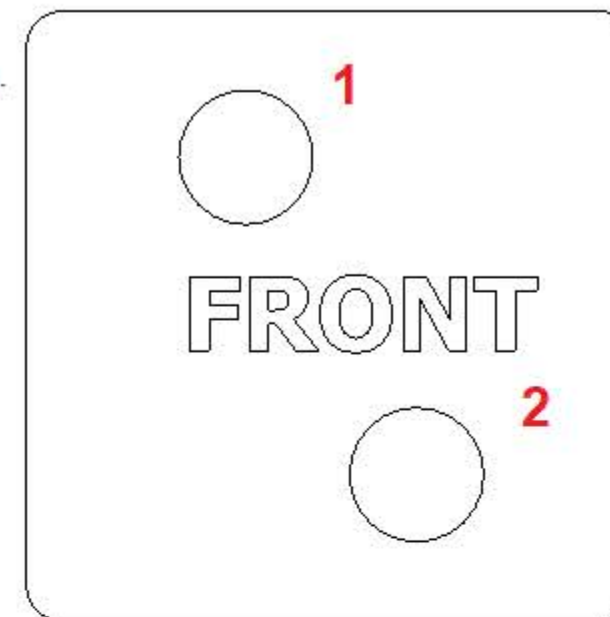
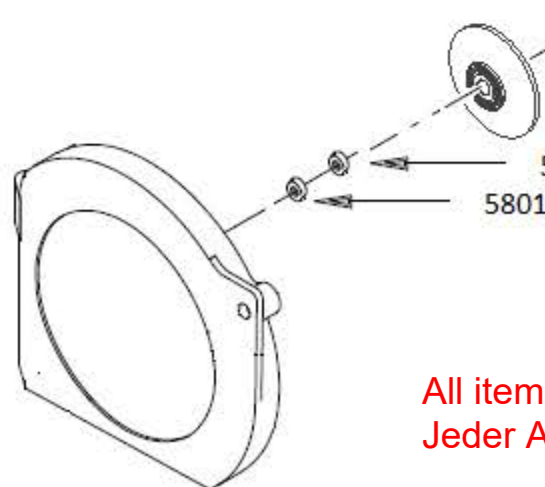

- 5800030616 - M6X16 UL.LO.HE.TO.CA.HE.GAL.SCREW
- 6900030024 + ASO910626 - PAPER GUARD ROLLER CAPRICORN + 626-2RSH BEARING
- 5801430033 - SHIM RING M6 UNI6592 - A2 STAINL.ST
- 5801430033 - SHIM RING M6 UNI6592 - A2 STAINL.ST

All items starting with ASK..., e.g. ASK6699940005
Jeder Artikel beginnt mit ASK..., z. B. ASK6699940005

	P/N machine: 6999940022	Page: 1 di 1	
	Description: MODIFICATION KIT FOR ABRASIVE PAPER	Edition: 05-2022	