



## spare parts list Jive 230V EU



## Table of contents

---

1 Jive 230V EU (04.2010 bis 09.2017)	3
1 Handel	4
2 Switch housing	6
3 Handle / Handle adjustment	8
4 Handle adjustment	10
5 Motor unit	12
6 Stator	14
7 Gear	16
8 Chassis / Machine case	18
9 Cleaning tank	20
10 Suction kit	22
11 Suction kit with bend	24
12 Electronic circuit diagram	26
2 Jive 230V EU (09.2017 bis heute)	28
1 Handel	29
2 Switch housing	31
3 Handle / Handle adjustment	33
4 Handle adjustment	35
5 Motor unit	37
6 Stator	39
7 Gear	41
8 Chassis / Machine case	43
9 Cleaning tank	45
10 Suction kit	47
11 Suction kit with bend	49
12 Electronic circuit diagram	51

## 1 Jive 230V EU (04.2010 bis 09.2017)

---

Item no.	Article no.	Description
1	01_01_056364	Handel
2	01_02_056364	Switch housing
3	01_03_056364	Handle / Handle adjustment
4	01_04_056364	Handle adjustment
5	01_05_056364	Motor unit
6	01_06_056364	Stator
7	01_07_056364	Gear
8	02_08_056364	Chassis / Machine case
9	01_09_056364	Cleaning tank
10	01_10_056364	Suction kit
11	01_11_056364	Suction kit with bend
12	01_12_056364	Electronic circuit diagram

# 1 Handel

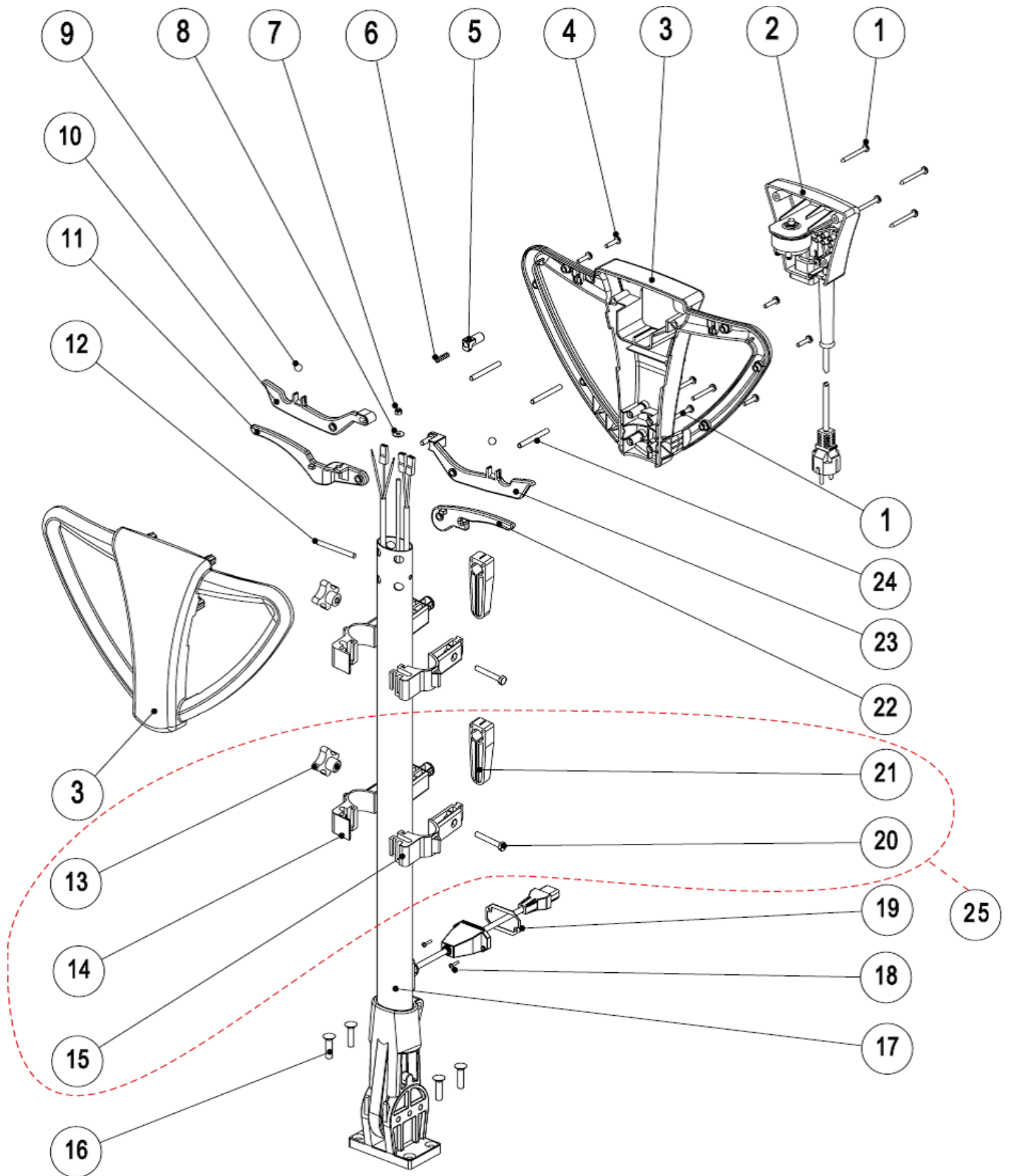



# 1 Handel

Item no.	Article no.	Description	Quantity
1	060113	Screw 5x50 Samba 2010	8
2	063958	Switch housing cpl.black Samba 2010	1
3	059711	Front & rear pistol stock 2010 green	1
4	060115	Screw 5x20 Samba 2010	8
5	060116	Push switch Samba 2010	1
6	060117	Pressure spring SAMBA 2010 / 6,2x27x0,6	1
7	014814	Stop hexagon nut M5 DIN 985	1
8	018321	Countersunk screw M5x25 DIN 7991 10.9	1
9	015446	Steel ball	2
10	086041	Lever-Set for switch Samba 2010	1
11	060132	Adjusting lever for shaft Samba 2010	1
12	060133	Split pin 6,0x63 Samba 2010	1
13	060134	Star grip screw M6 Samba 2010/Uno	2
14	060140	Clamp tank right Samba 2010/Uno	2
15	060141	Clamp tank left Samba 2010/Uno	2
16	014761	Countersunk screw M8x25 DIN 7991 10.9	4
17	059712	Bar for handle oval Samba 2010	1
18	060135	Screw 3,2x20 Samba 2010	2
19	060138	Sealing plug Samba 2010	1
20	018161	Hexagon head screw M 6x45 DIN 931	2
21	060136	Readjusting part Samba 2010/Uno	2
22	060137	Lever for water supply Samba 2010	1
23	086041	Lever-Set for switch Samba 2010	1
24	060139	Split pin 6,0x58 Samba 2010	3
25	078085	Clamp tank complete Samba 2010	1

## 2 Switch housing

---

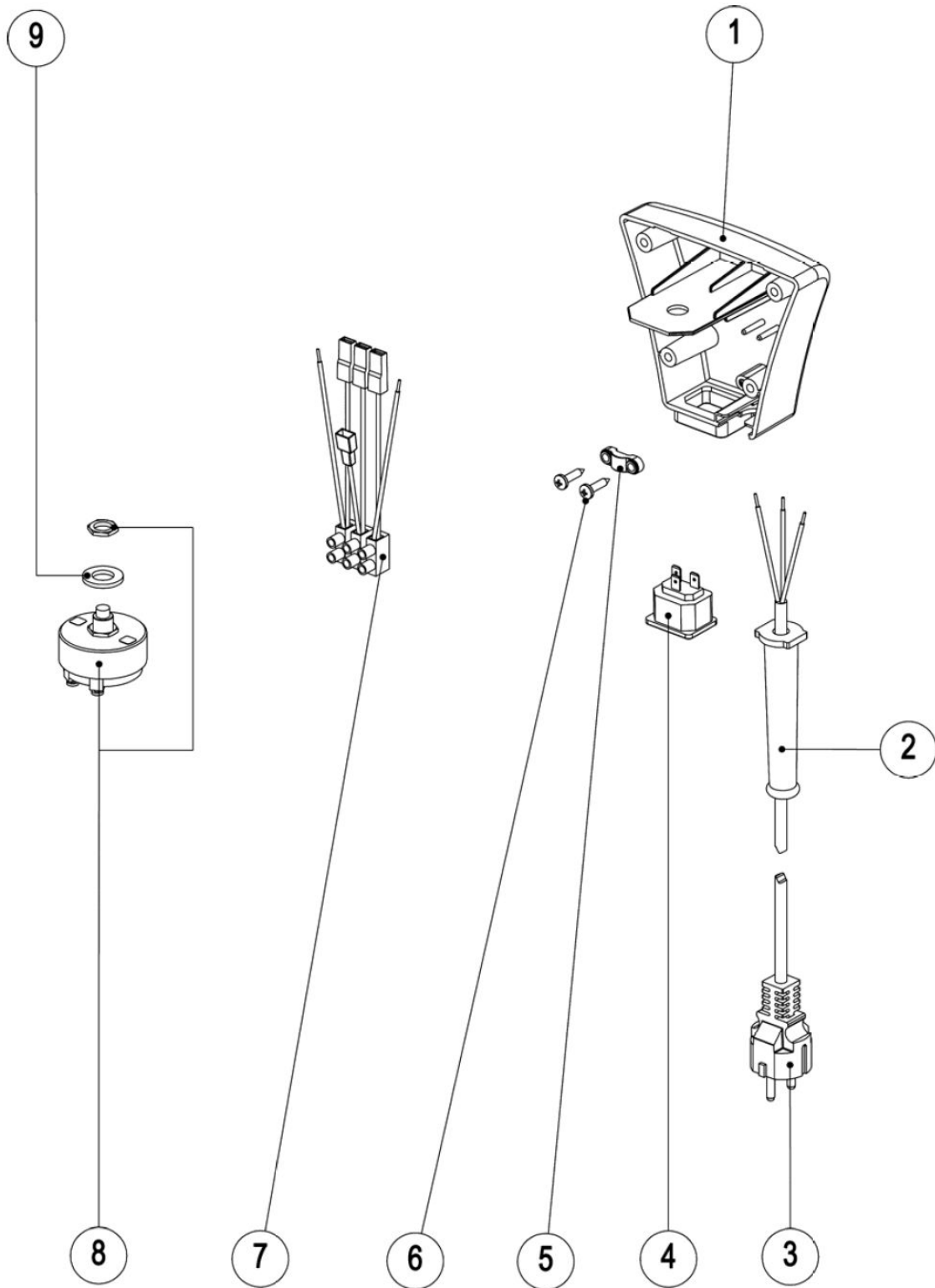

## 2 Switch housing

---

Item no.	Article no.	Description	Quantity
1	063957	Housing black Samba 2010	1
2	015498	Protective rubber sleeve	1
3	067390	Cord 3G1,5x10m green with plug	1
4	033965	Plug socket	1
5	015496	Cable clamp	1
6	018332	Countersunk screw M3x10 DIN 965	2
7	165139	Cable set with clamps Samba 2010	1
8	015514	Switch for grinding machine W1700	1
9	014830	Washer M12 DIN 125 A	1

### 3 Handle / Handle adjustment

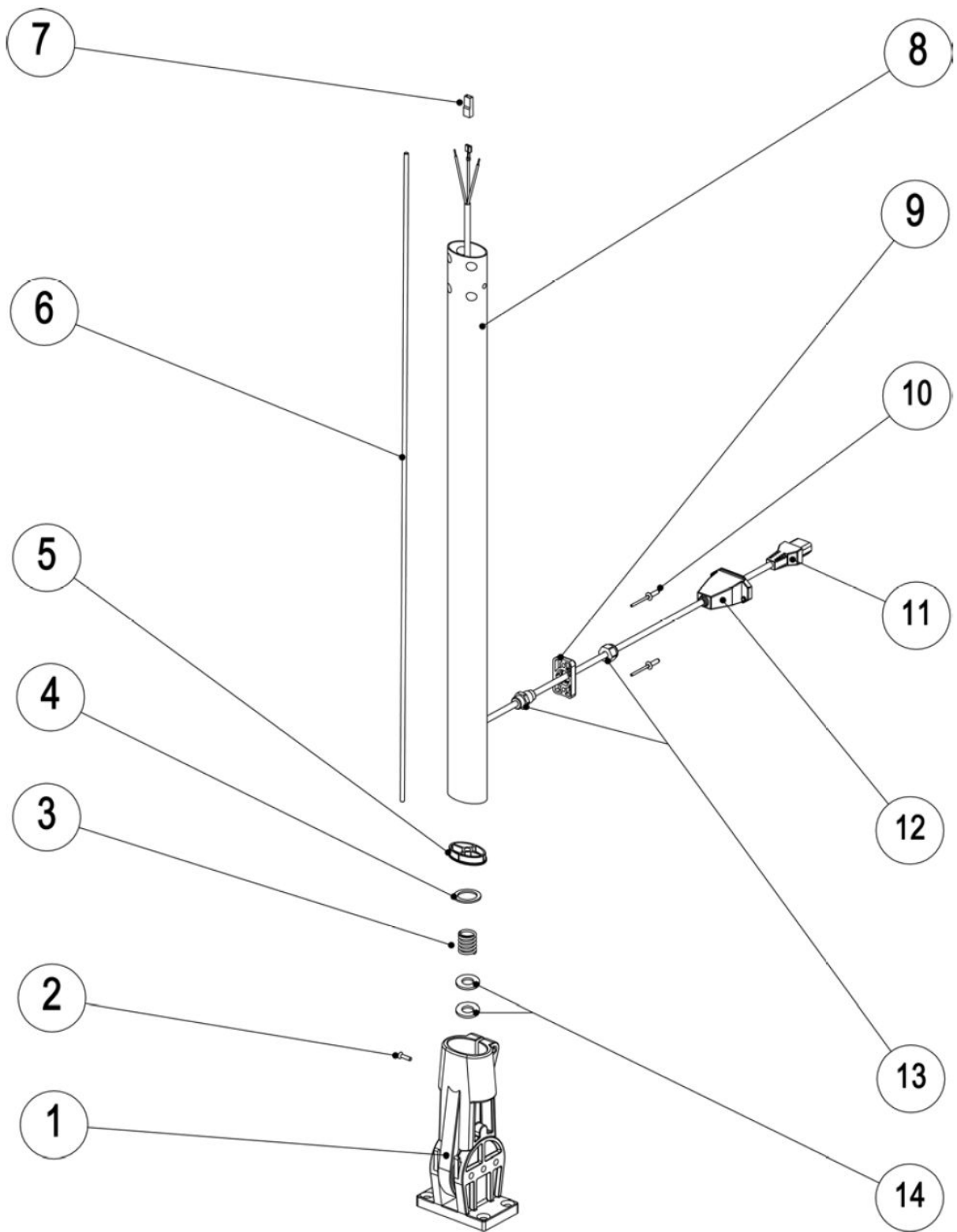

### 3 Handle / Handle adjustment

Item no.	Article no.	Description	Quantity
1	060291	Tilting joint complete Samba 2010	1
2	015468	Screw M4x16 for retention pin	1
3	015461	Pressure spring 21x35x2,4 W1700	1
4	060293	Sealing ring Samba 2010	1
5	060287	Stopper Samba 2010	1
6	015455	Pull rod for shaft adjustment W1700	1
7	060288	Plug grounding Samba 2010	1
8	059712	Bar for handle oval Samba 2010	1
9	060290	Cable support Samba 2010	1
10	060289	Rivet 4,8x15 Samba 2010	2
11	014195	Cable in shaft	1
12	033962	Cover Plug	1
13	019180	Bolt joint PG 9	1
14	014831	Washer 16mm DIN 125	2

## 4 Handle adjustment

---

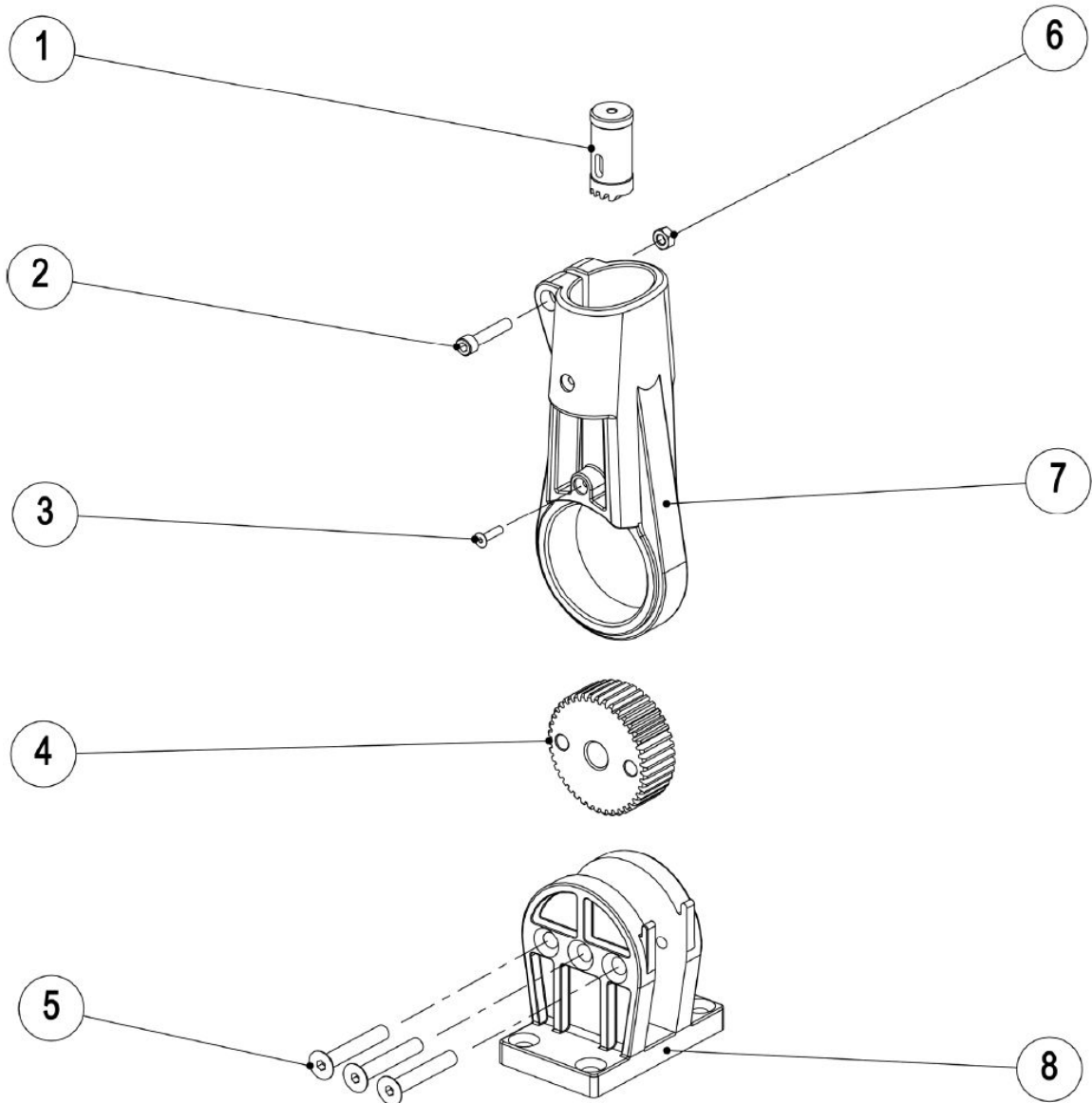

## 4 Handle adjustment

---

Item no.	Article no.	Description	Quantity
1	015462	Piston for gear rim	1
2	017678	Cylinder head screw M6x30 DIN 912	1
3	015468	Screw M4x16 for retention pin	1
4	015463	Gear rim	1
5	017631	Counter sunk screw M8X50 DIN 7991 10.9	3
6	014809	Hexagon nut M6 DIN 934	1
7	059713	Joint Samba Tango 2010	1
8	015464	Fork-shaped piece for attachmen	1

# 5 Motor unit

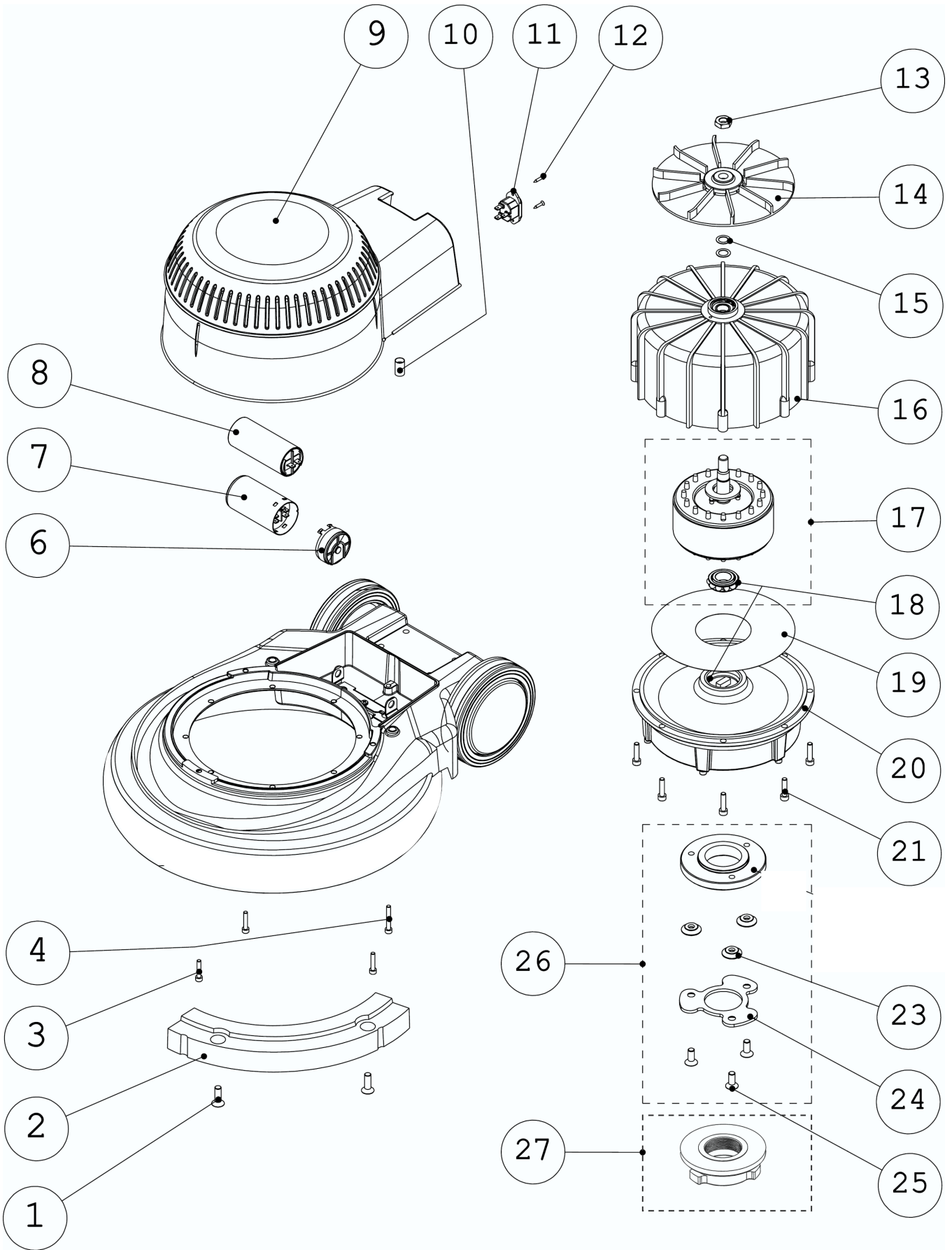



## 5 Motor unit

Item no.	Article no.	Description	Quantity
1	017116	Countersunk screw M8x30 10.9 DIN 7991	2
2	021628	Balancing weight Samba/Tango/UNO	1
3	014722	Cylinder head screw M 5x25 DIN 912	3
4	017007	Cylinder head screw M5x35 DIN912	1
6	060218	Cover copacitor Samba 2010	1
7	015503	Capacitor 140 µF Samba	1
8	015505	Operating condenser 31.5 MF	1
9	067713	Motor housing cover Flamenco/Samba	1
10		Spacer bushing	1
11	015502	Socket	1
12	042472	Selftapping convex head screw 2,9x19 DIN	2
13	015478	Nut for fan wheel	1
14	015480	Fan wheel	1
15	018080	Shim ring 12x18x0,5 DIN 988	2
16	021656	Stator C43 (230V/50Hz)	1
17	021657	Rotor C43 (230V)	1
18	015486	Bearing 6002 W 1700	1
19	015485	Insulated disc large W1700	1
20	036560	Transmission compl.Jive	1
21	018264	Cylinder head screw M 6x35 DIN 912	8
23	021635	Distance spacer	3
24	015401	Clutch flange Mambo/Samba	1
25	014760	Countersunk screw M8x20 DIN 7991 10.9	3
26	060219	Hub complet Samba 2010	1
27	069507	Coupling Clarke Samba	1

## 6 Stator

---

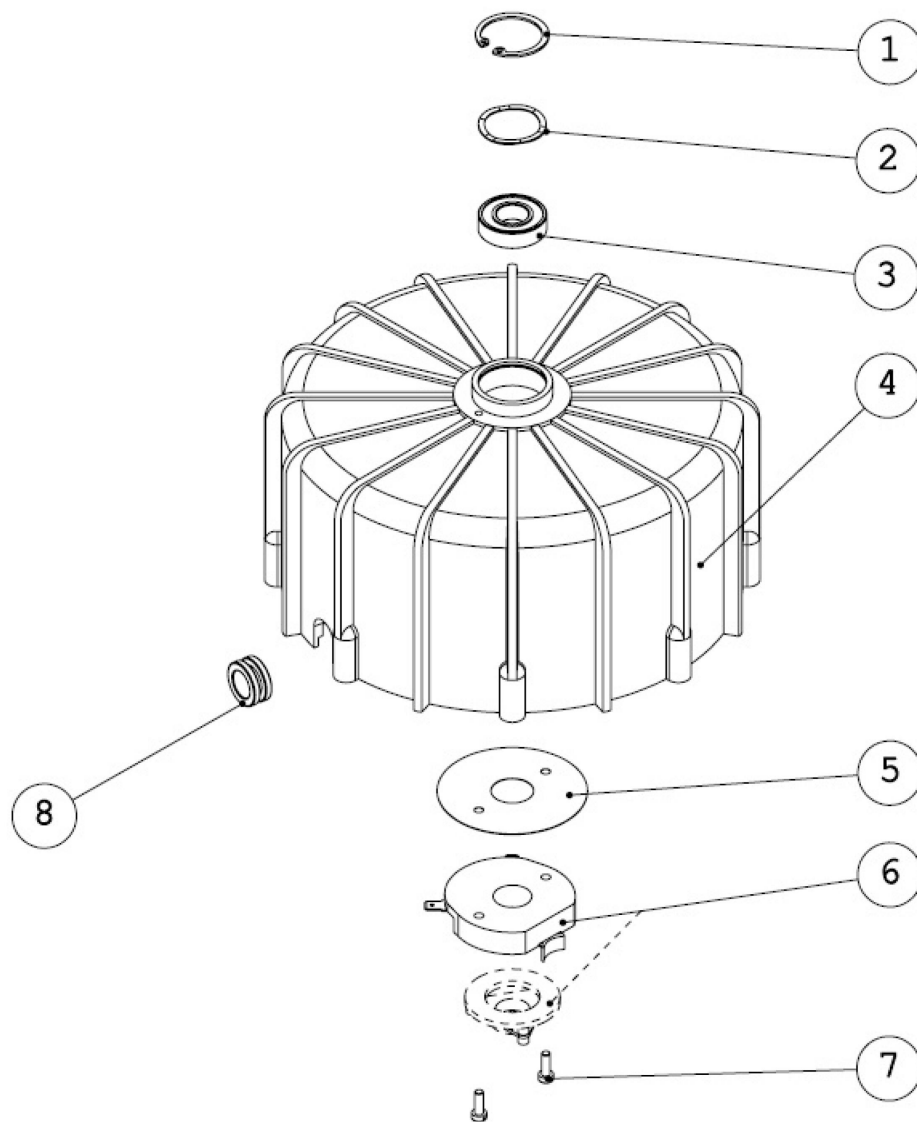

## 6 Stator

---

Item no.	Article no.	Description	Quantity
1	014854	Safety washer I32 DIN 472	1
2		Washer	1
3	014702	Ball-bearing 6002 2RS	1
4	021656	Stator C43 (230V/50Hz)	1
5	018417	Insulated disc small W1700	1
6	015483	Centrifugal switch	1
7	015481	Screw M 4x 12 DIN 84	2
8	015498	Protective rubber sleeve	1

# 7 Gear

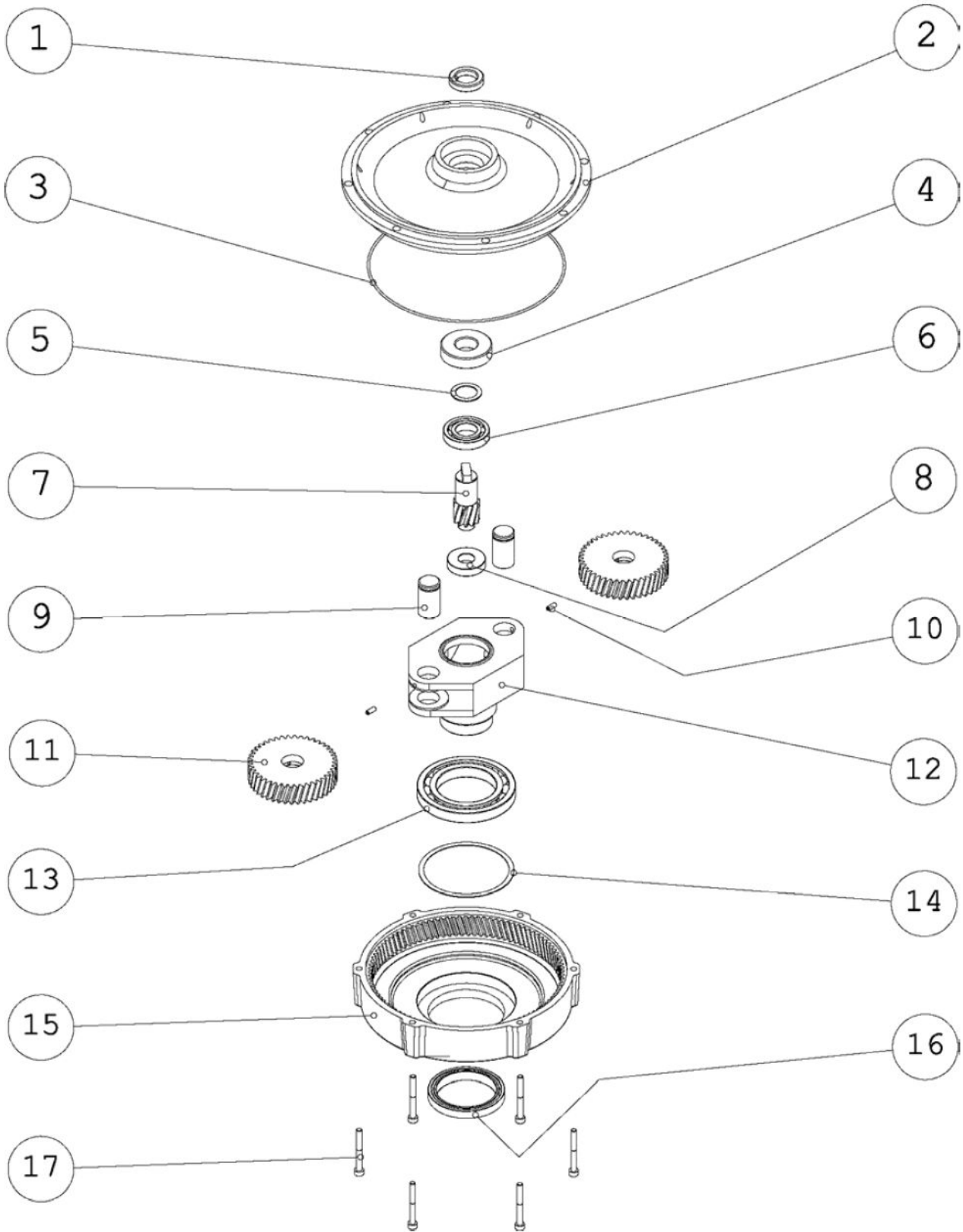

## 7 Gear

Item no.	Article no.	Description	Quantity
1	015507	Shaft sealing ring 20x32x7 W1700	1
2	033963	Cover transmission	1
3	018422	O-Ring	1
4	015489	Bearing E-20	1
5	014841	Shim ring 20x28x1 DIN 988	1
6	018425	Bearing 16-004 W1700	1
7	036559	Gear wheel Jive	1
8	018426	Bearing E.15 W1700	1
9	015508	Bolt	2
10	018219	Thread pin M4x10 DIN 914	2
11	036571	Gear wheel transmission Jive	2
12	018427	Gear holder W1700	1
13	018428	Bearing 16-011 W1700	1
14	015511	Ball bearing washer KAS 90	1
15	034268	Gear block housing	1
16	015510	Shaft sealing ring 55x70x8 W1700	1
17	060220	Cylinder head screw M5x45 10.9 micro	6

## 8 Chassis / Machine case

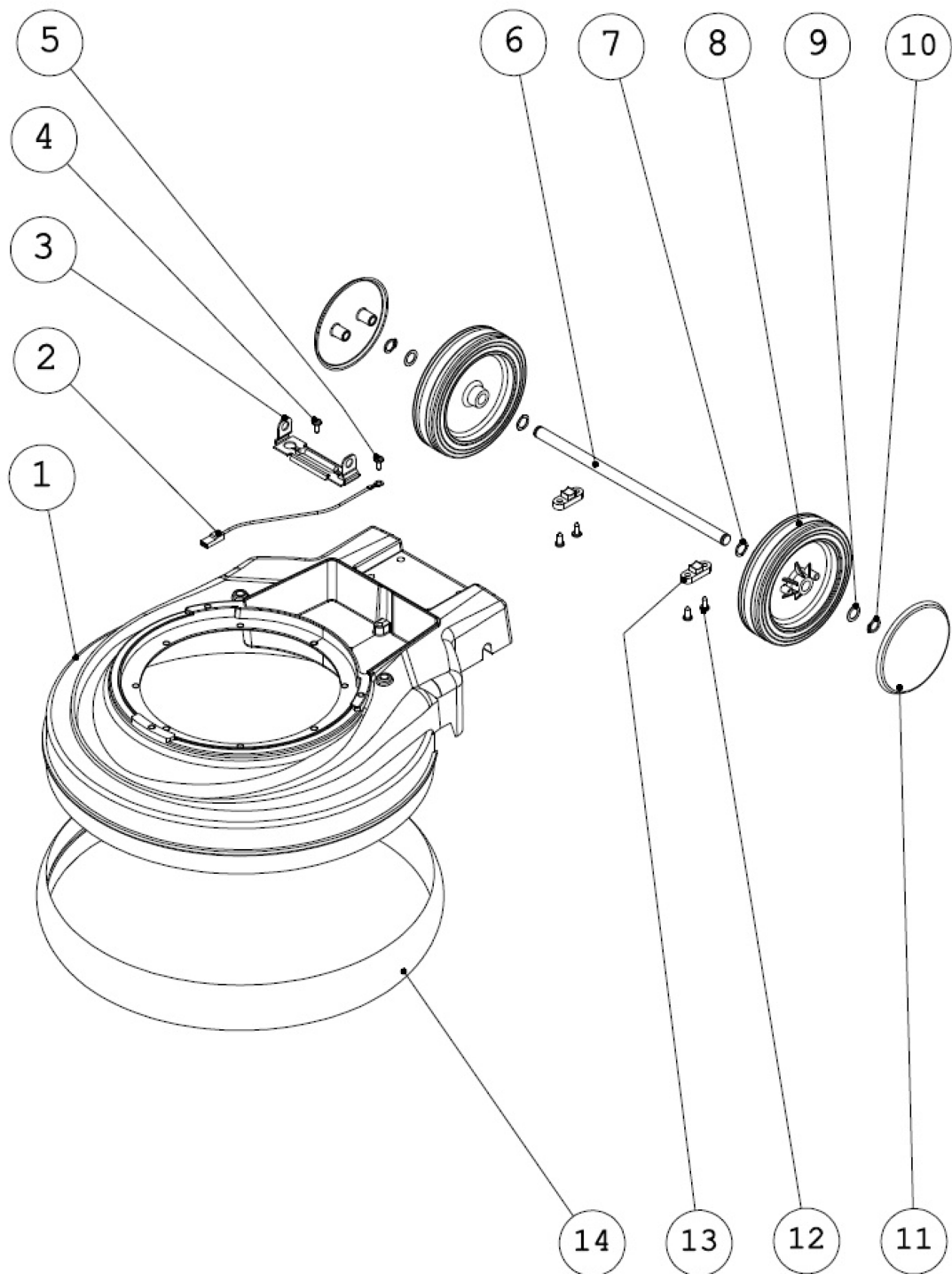

## 8 Chassis / Machine case

Item no.	Article no.	Description	Quantity
1	060273	Housing bottom part dark grey 2010	1
2	060255	Ground wire Samba 2010	1
3	060256	Holdig device condenser Samba 2010	1
4	015504	Lens head screw M5x10 DIN 7985	1
5		Screw 5x6	2
6	021631	not available SEE 083950	1
7	018080	not available SEE 083950	2
8	060272	not available SEE 083950	2
9	014830	not available SEE 083950	2
10	014849	not available SEE 083950	2
11	021633	not available SEE 083950	2
12	017284	not available SEE 083950	4
13	017283	not available SEE 083950	2
14	015358	Rubber bumpers light grey	1

## 9 Cleaning tank

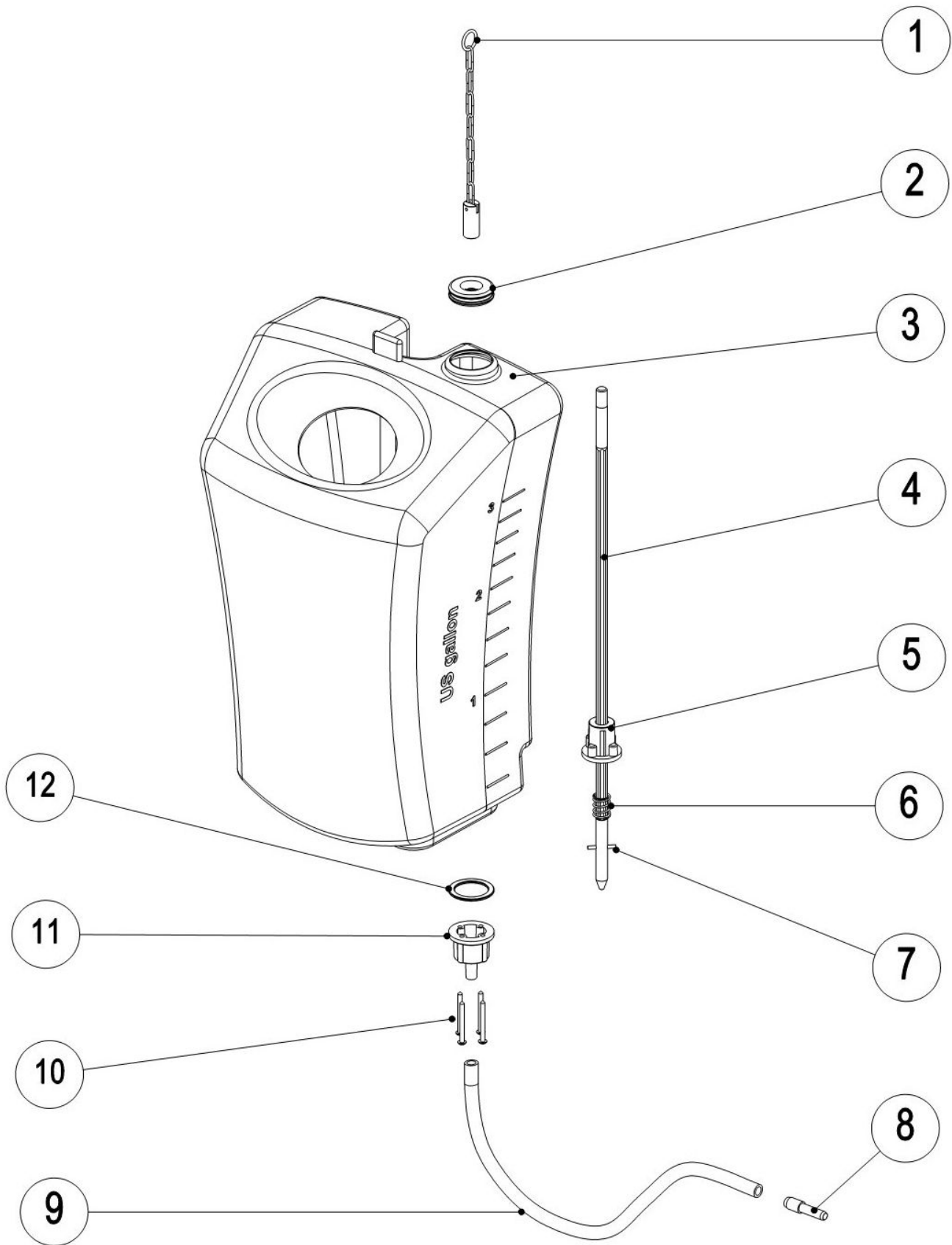



## 9 Cleaning tank

Item no.	Article no.	Description	Quantity
1	072889	Chain f.cleaning tank Samba	1
2		Sealing Top	1
3		Tank housing	1
4		Rod	1
5	017493	Half valve for W1700	1
6		Spring	1
7		Pin	1
8	018433	end fitting f.hose cleaning tank	1
9	018647	Hose for tank	1
10		Screw	4
11	017048	Lower half of valve	1
12		Sealing below	1
13	059831	Cleaning tank complete Samba 2010	1

## 10 Suction kit

---

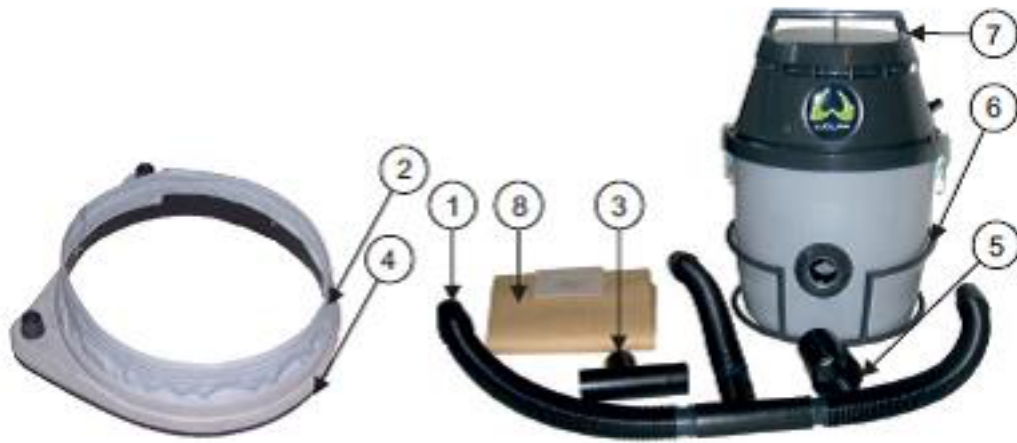

## 10 Suction kit

Item no.	Article no.	Description	Quantity
1	014038	Hose kit with T adapter	1
2	014039	Suction ring with sealing shell	1
3	015352	T-piece exhaust 390	1
4	015353	Brush ring f. suction kit	1
5	015354	Connecting piece f.exhaust 390	1
6	015355	Basket for Vacuum Samba/Tango	1
7	035082	Vacuum cleaner 230V/50Hz Samba/Tango	1
8	037299	Paper filter bags 80cm f.13503 5p/PU	1

## 11 Suction kit with bend

---



## 11 Suction kit with bend

---

Item no.	Article no.	Description	Quantity
1	035082	Vacuum cleaner 230V/50Hz Samba/Tango	1
2	073385	Connection hose cpl.	1
3	072462	Dust seal with elbow Samba	1
4	078742	Brush f. dust seal with elbow	1
5	072465	Bumper dust proof ring Samba	1

## 12 Electronic circuit diagram

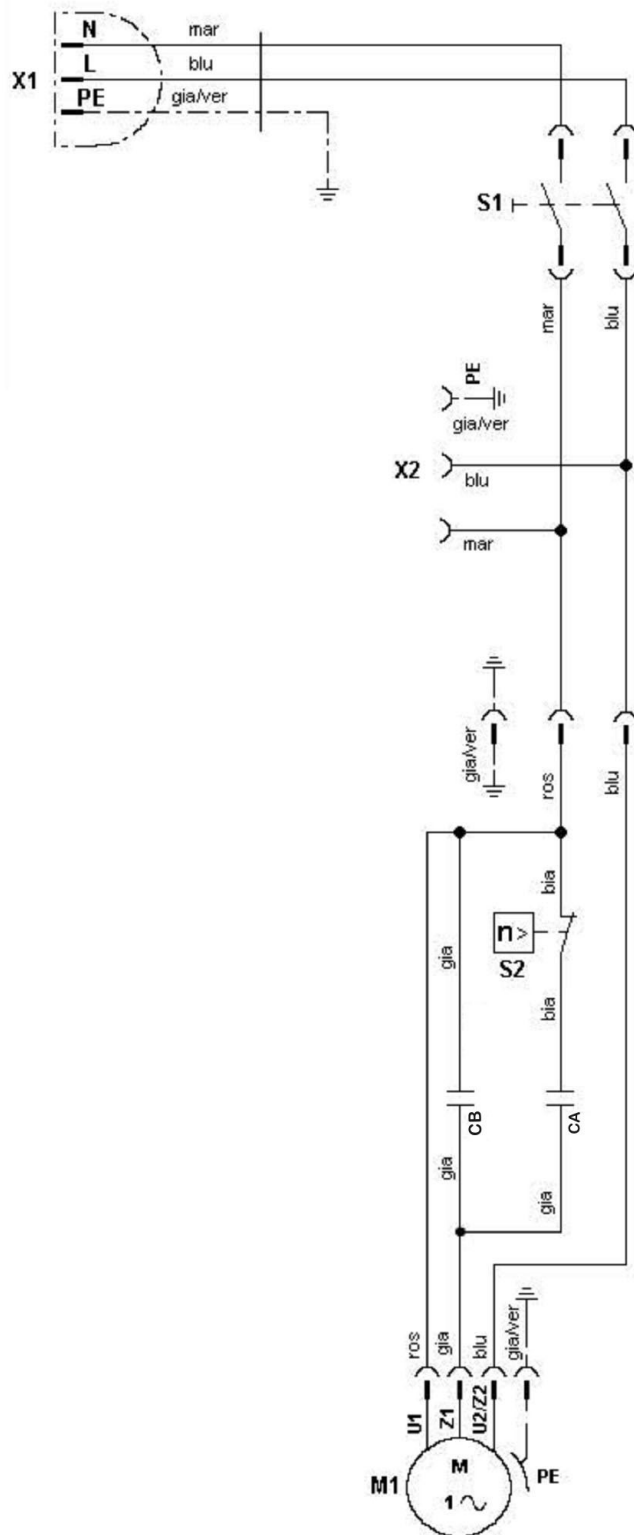

<b>GB</b>	<b>CB</b> OPERATING CAPACITOR
	<b>CA</b> START CAPACITOR
	<b>S2</b> TACHOMETRIC START CAPACITOR
	<b>M1</b> BRUSH ELECTRIC MOTOR
	<b>S1</b> MAIN POWER SWITCH
	<b>X1</b> POWER PLUG
	<b>X2</b> AUXILIAR SOCKET

ros	rosso	red
bia	bianco	white
mar	marrone	brown
blu	blu	blue
gia	giallo	yellow
ver	verde	green

## 12 Electronic circuit diagram

---

## 2 Jive 230V EU (09.2017 bis heute)

---

Item no.	Article no.	Description
1	01_01_056364	Handel
2	01_02_056364	Switch housing
3	01_03_056364	Handle / Handle adjustment
4	01_04_056364	Handle adjustment
5	01_05_056364	Motor unit
6	01_06_056364	Stator
7	01_07_056364	Gear
8	01_08_056364	Chassis / Machine case
9	01_09_056364	Cleaning tank
10	01_10_056364	Suction kit
11	01_11_056364	Suction kit with bend
12	01_12_056364	Electronic circuit diagram



# 1 Handel

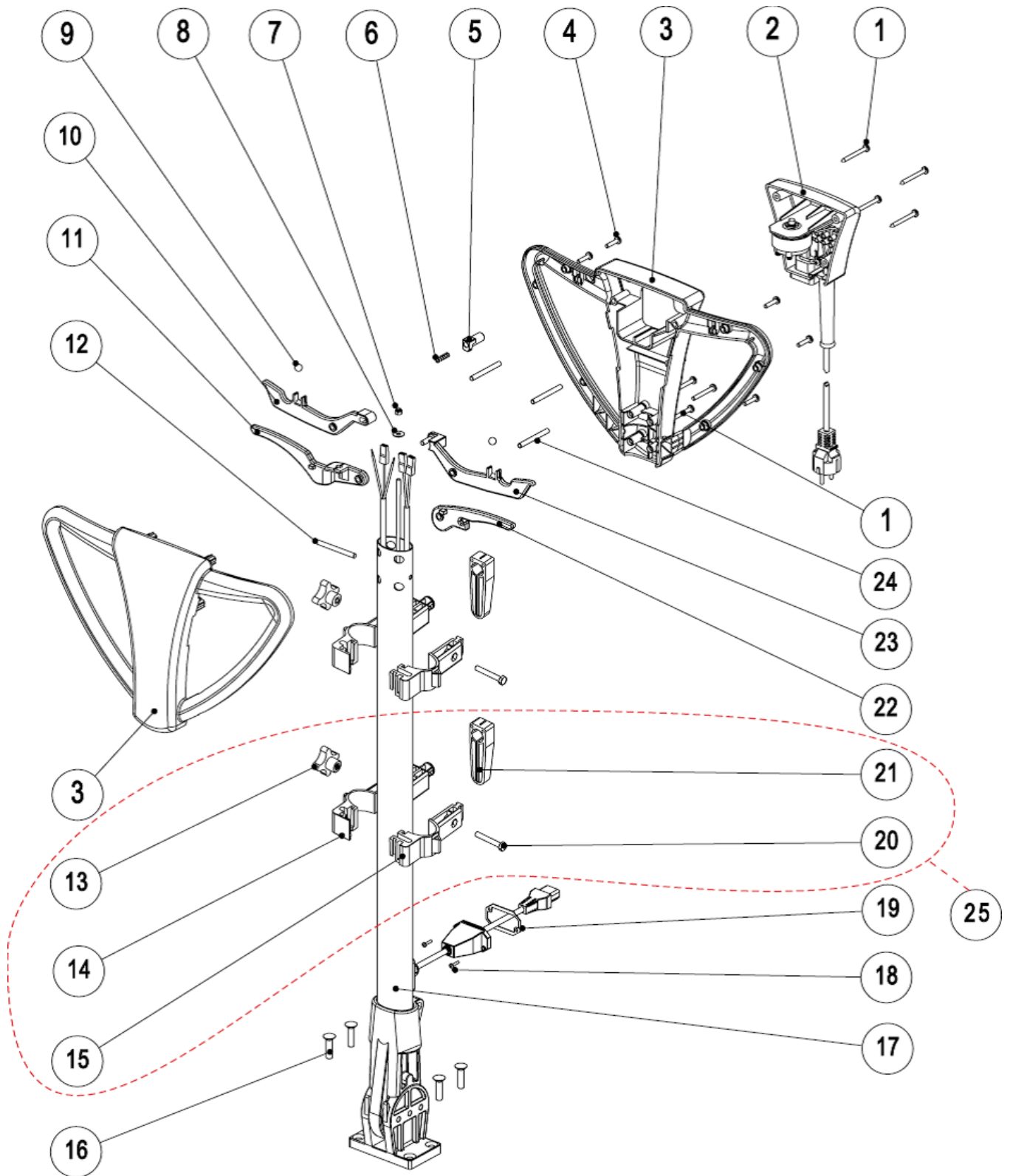

## 1 Handel

Item no.	Article no.	Description	Quantity
1	060113	Screw 5x50 Samba 2010	8
2	063958	Switch housing cpl.black Samba 2010	1
3	059711	Front & rear pistol stock 2010 green	1
4	060115	Screw 5x20 Samba 2010	8
5	060116	Push switch Samba 2010	1
6	060117	Pressure spring SAMBA 2010 / 6,2x27x0,6	1
7	014814	Stop hexagon nut M5 DIN 985	1
8	018321	Countersunk screw M5x25 DIN 7991 10.9	1
9	015446	Steel ball	2
10	086041	Lever-Set for switch Samba 2010	1
11	060132	Adjusting lever for shaft Samba 2010	1
12	060133	Split pin 6,0x63 Samba 2010	1
13	060134	Star grip screw M6 Samba 2010/Uno	2
14	060140	Clamp tank right Samba 2010/Uno	2
15	060141	Clamp tank left Samba 2010/Uno	2
16	014761	Countersunk screw M8x25 DIN 7991 10.9	4
17	059712	Bar for handle oval Samba 2010	1
18	060135	Screw 3,2x20 Samba 2010	2
19	060138	Sealing plug Samba 2010	1
20	018161	Hexagon head screw M 6x45 DIN 931	2
21	060136	Readjusting part Samba 2010/Uno	2
22	060137	Lever for water supply Samba 2010	1
23	086041	Lever-Set for switch Samba 2010	1
24	060139	Split pin 6,0x58 Samba 2010	3
25	078085	Clamp tank complete Samba 2010	1

## 2 Switch housing

---

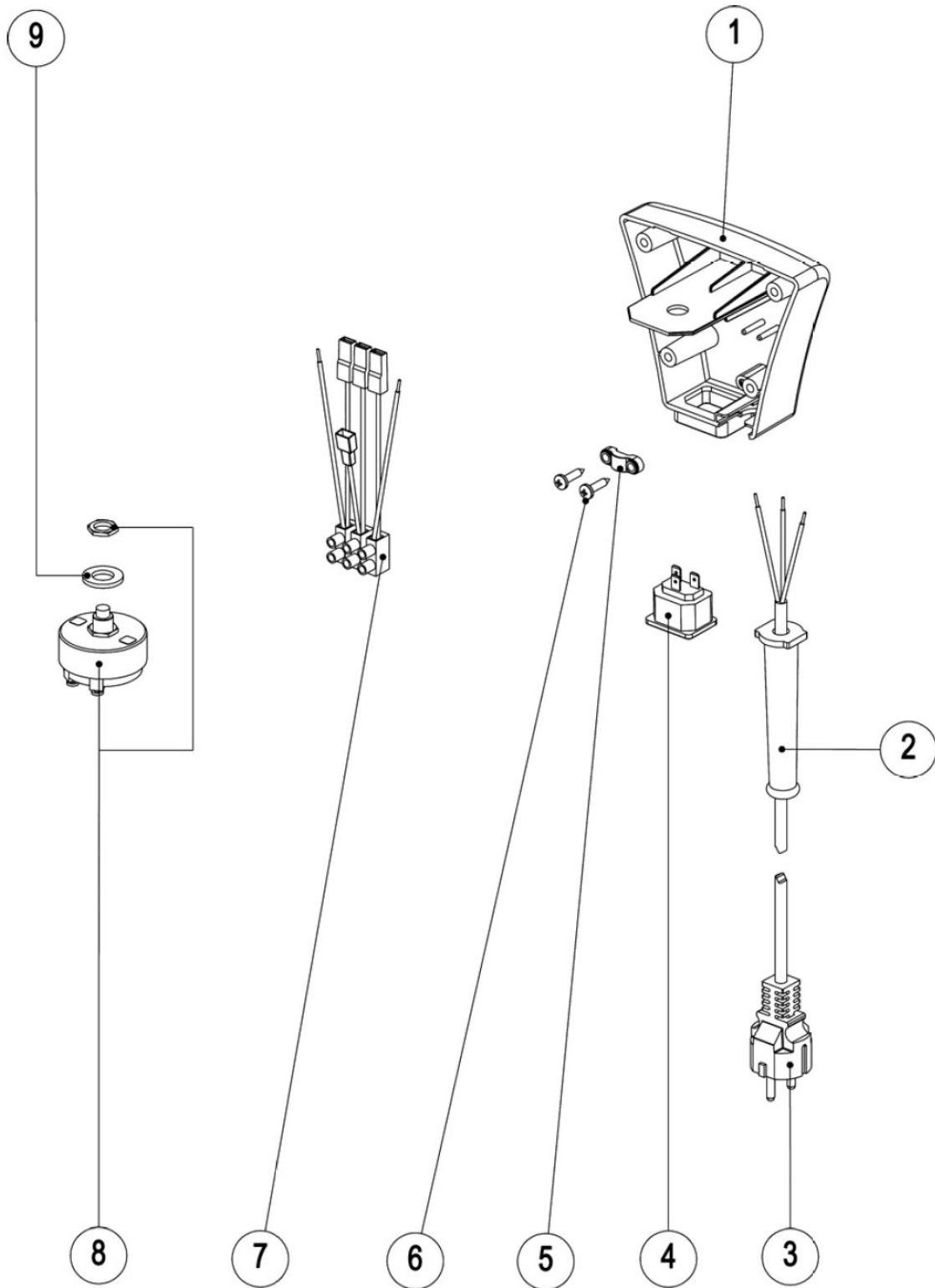

## 2 Switch housing

---

Item no.	Article no.	Description	Quantity
1	063957	Housing black Samba 2010	1
2	015498	Protective rubber sleeve	1
3	067390	Cord 3G1,5x10m green with plug	1
4	033965	Plug socket	1
5	015496	Cable clamp	1
6	018332	Countersunk screw M3x10 DIN 965	2
7	165139	Cable set with clamps Samba 2010	1
8	015514	Switch for grinding machine W1700	1
9	014830	Washer M12 DIN 125 A	1

### 3 Handle / Handle adjustment

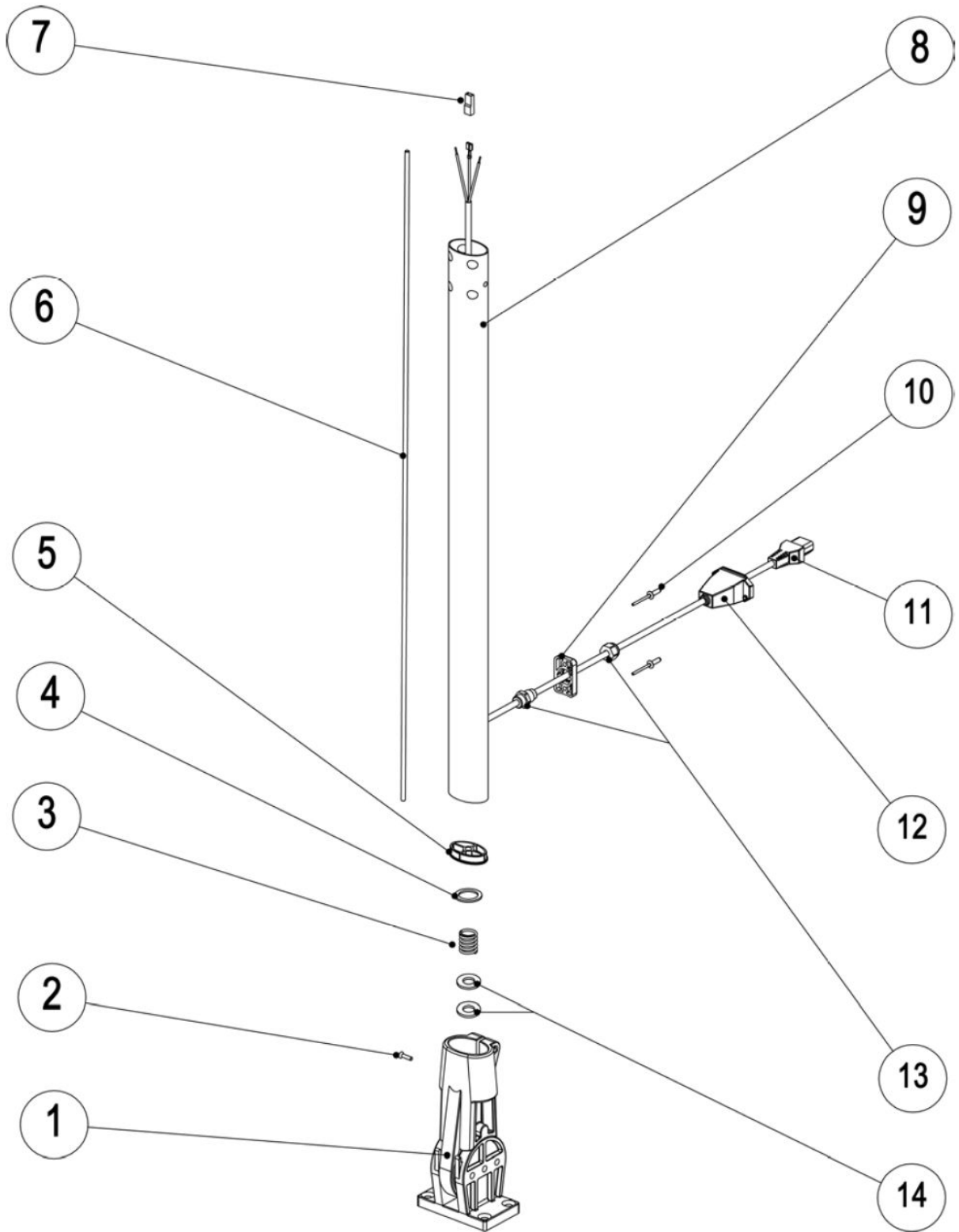

### 3 Handle / Handle adjustment

Item no.	Article no.	Description	Quantity
1	060291	Tilting joint complete Samba 2010	1
2	015468	Screw M4x16 for retention pin	1
3	015461	Pressure spring 21x35x2,4 W1700	1
4	060293	Sealing ring Samba 2010	1
5	060287	Stopper Samba 2010	1
6	015455	Pull rod for shaft adjustment W1700	1
7	060288	Plug grounding Samba 2010	1
8	059712	Bar for handle oval Samba 2010	1
9	060290	Cable support Samba 2010	1
10	060289	Rivet 4,8x15 Samba 2010	2
11	014195	Cable in shaft	1
12	033962	Cover Plug	1
13	019180	Bolt joint PG 9	1
14	014831	Washer 16mm DIN 125	2

## 4 Handle adjustment

---

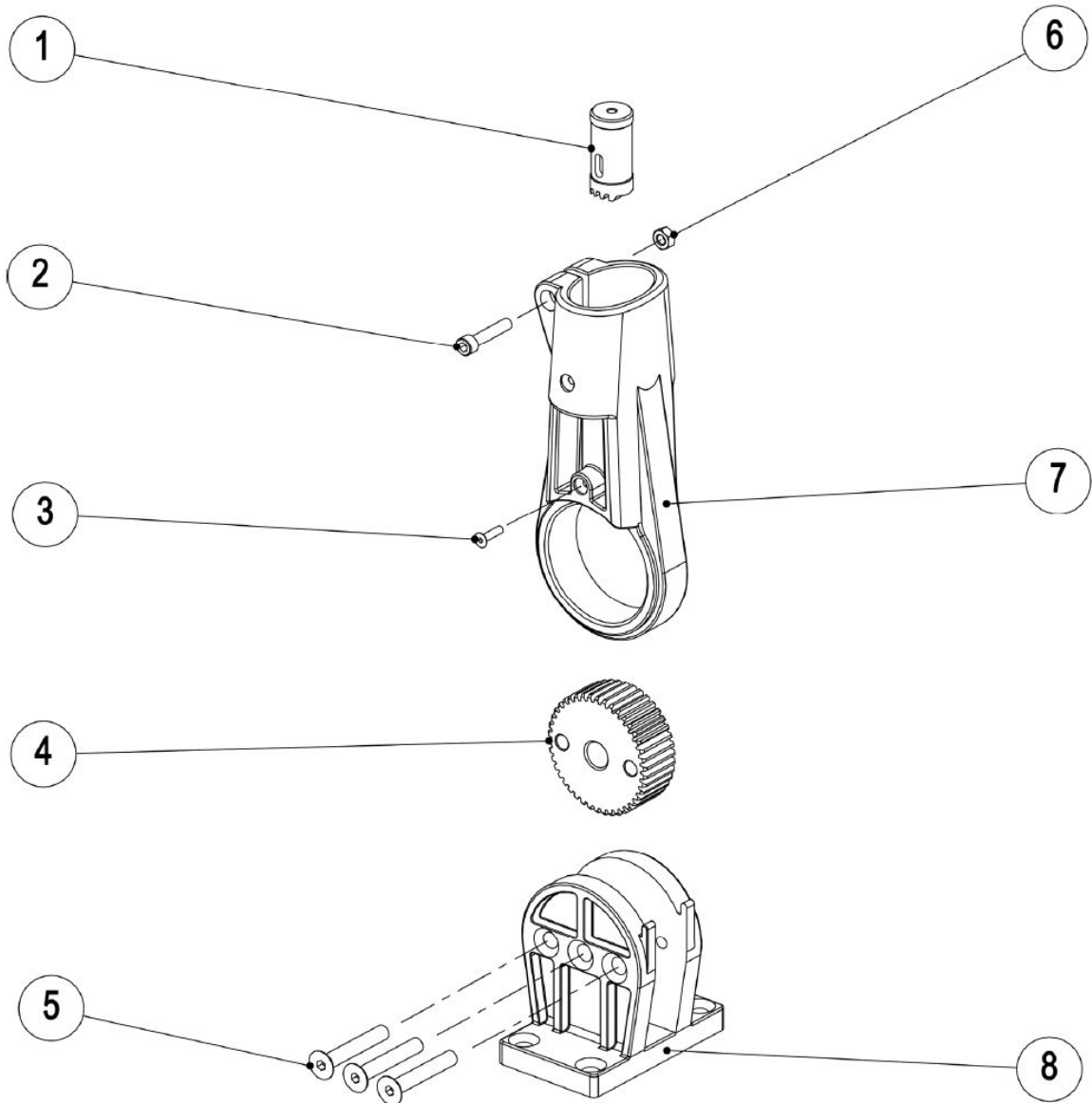

## 4 Handle adjustment

---

Item no.	Article no.	Description	Quantity
1	015462	Piston for gear rim	1
2	017678	Cylinder head screw M6x30 DIN 912	1
3	015468	Screw M4x16 for retention pin	1
4	015463	Gear rim	1
5	017631	Counter sunk screw M8X50 DIN 7991 10.9	3
6	014809	Hexagon nut M6 DIN 934	1
7	059713	Joint Samba Tango 2010	1
8	015464	Fork-shaped piece for attachmen	1



# 5 Motor unit

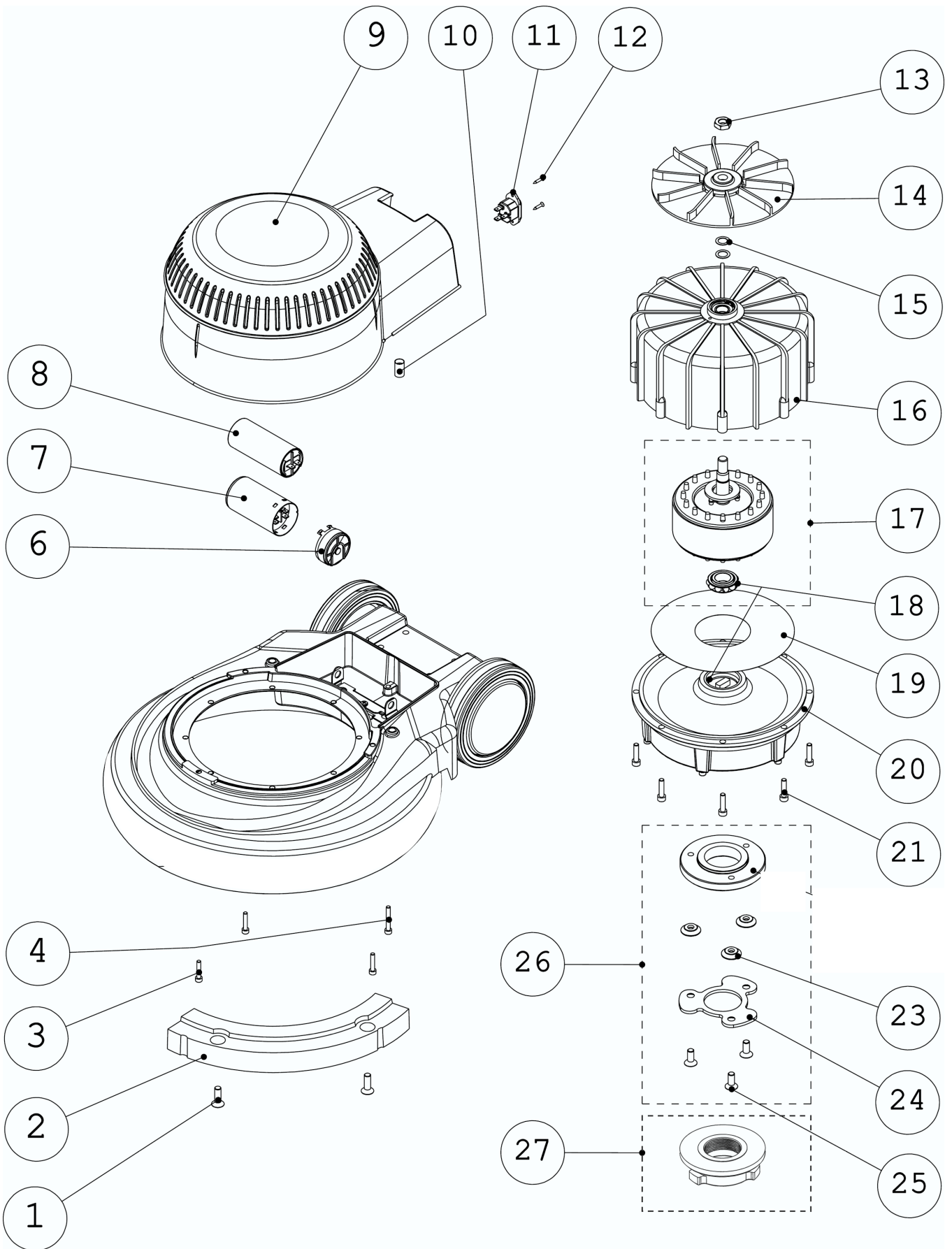

## 5 Motor unit

Item no.	Article no.	Description	Quantity
1	017116	Countersunk screw M8x30 10.9 DIN 7991	2
2	021628	Balancing weight Samba/Tango/UNO	1
3	014722	Cylinder head screw M 5x25 DIN 912	3
4	017007	Cylinder head screw M5x35 DIN912	1
6	060218	Cover copacitor Samba 2010	1
7	015503	Capacitor 140 µF Samba	1
8	015505	Operating condenser 31.5 MF	1
9	067713	Motor housing cover Flamenco/Samba	1
10		Spacer bushing	1
11	015502	Socket	1
12	042472	Selftapping convex head screw 2,9x19 DIN	2
13	015478	Nut for fan wheel	1
14	015480	Fan wheel	1
15	018080	Shim ring 12x18x0,5 DIN 988	2
16	021656	Stator C43 (230V/50Hz)	1
17	021657	Rotor C43 (230V)	1
18	015486	Bearing 6002 W 1700	1
19	015485	Insulated disc large W1700	1
20	036560	Transmission compl.Jive	1
21	018264	Cylinder head screw M 6x35 DIN 912	8
23	021635	Distance spacer	3
24	015401	Clutch flange Mambo/Samba	1
25	014760	Countersunk screw M8x20 DIN 7991 10.9	3
26	060219	Hub complet Samba 2010	1
27	069507	Coupling Clarke Samba	1

## 6 Stator

---

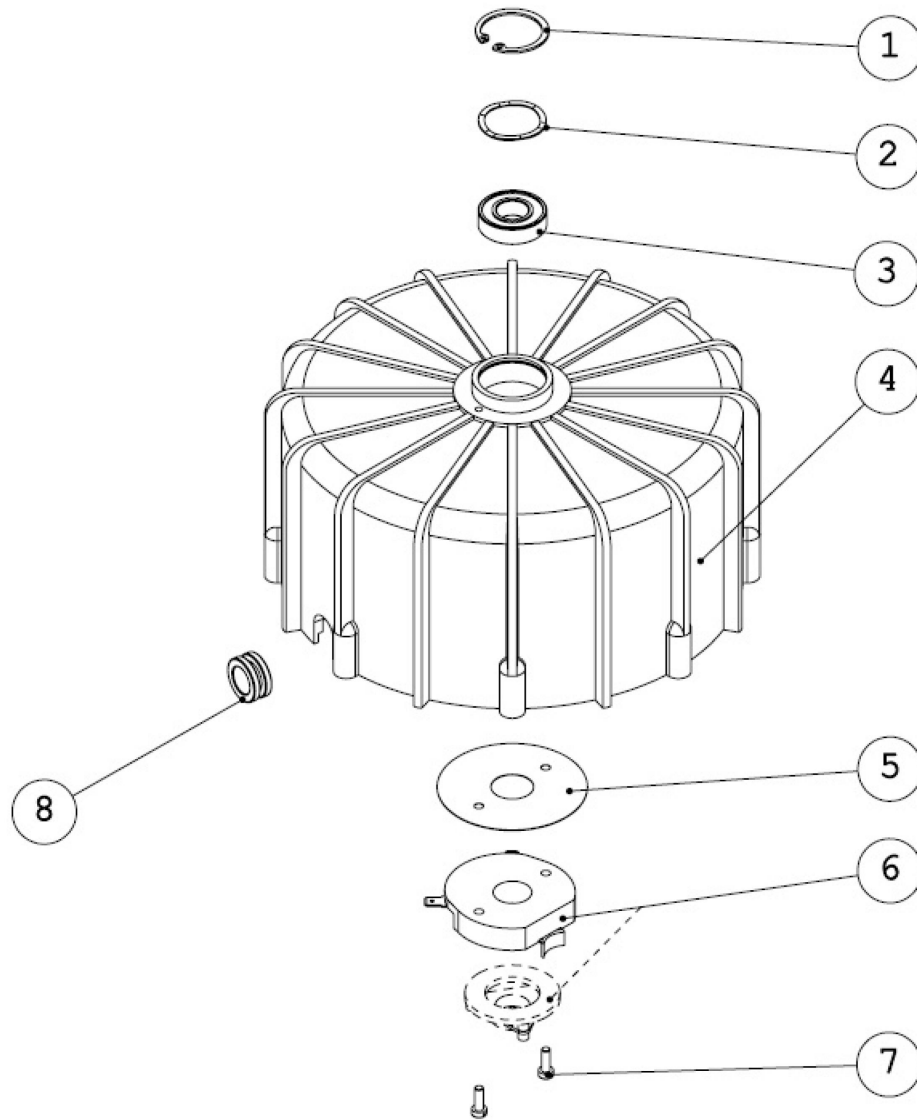

## 6 Stator

---

Item no.	Article no.	Description	Quantity
1	014854	Safety washer I32 DIN 472	1
2		Washer	1
3	014702	Ball-bearing 6002 2RS	1
4	021656	Stator C43 (230V/50Hz)	1
5	018417	Insulated disc small W1700	1
6	015483	Centrifugal switch	1
7	015481	Screw M 4x 12 DIN 84	2
8	015498	Protective rubber sleeve	1

# 7 Gear

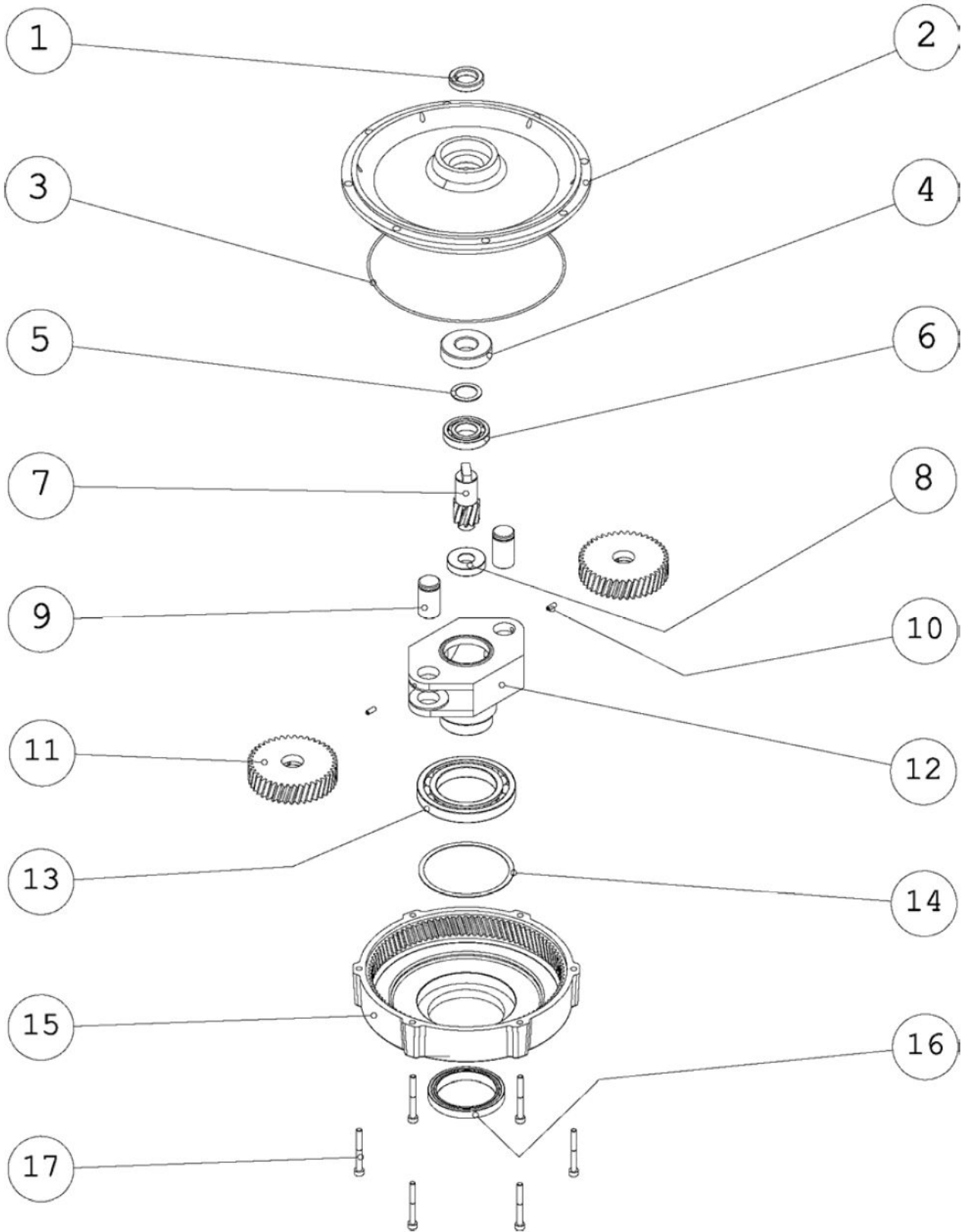

## 7 Gear

Item no.	Article no.	Description	Quantity
1	015507	Shaft sealing ring 20x32x7 W1700	1
2	033963	Cover transmission	1
3	018422	O-Ring	1
4	015489	Bearing E-20	1
5	014841	Shim ring 20x28x1 DIN 988	1
6	018425	Bearing 16-004 W1700	1
7	036559	Gear wheel Jive	1
8	018426	Bearing E.15 W1700	1
9	015508	Bolt	2
10	018219	Thread pin M4x10 DIN 914	2
11	036571	Gear wheel transmission Jive	2
12	018427	Gear holder W1700	1
13	018428	Bearing 16-011 W1700	1
14	015511	Ball bearing washer KAS 90	1
15	034268	Gear block housing	1
16	015510	Shaft sealing ring 55x70x8 W1700	1
17	060220	Cylinder head screw M5x45 10.9 micro	6

## 8 Chassis / Machine case

---

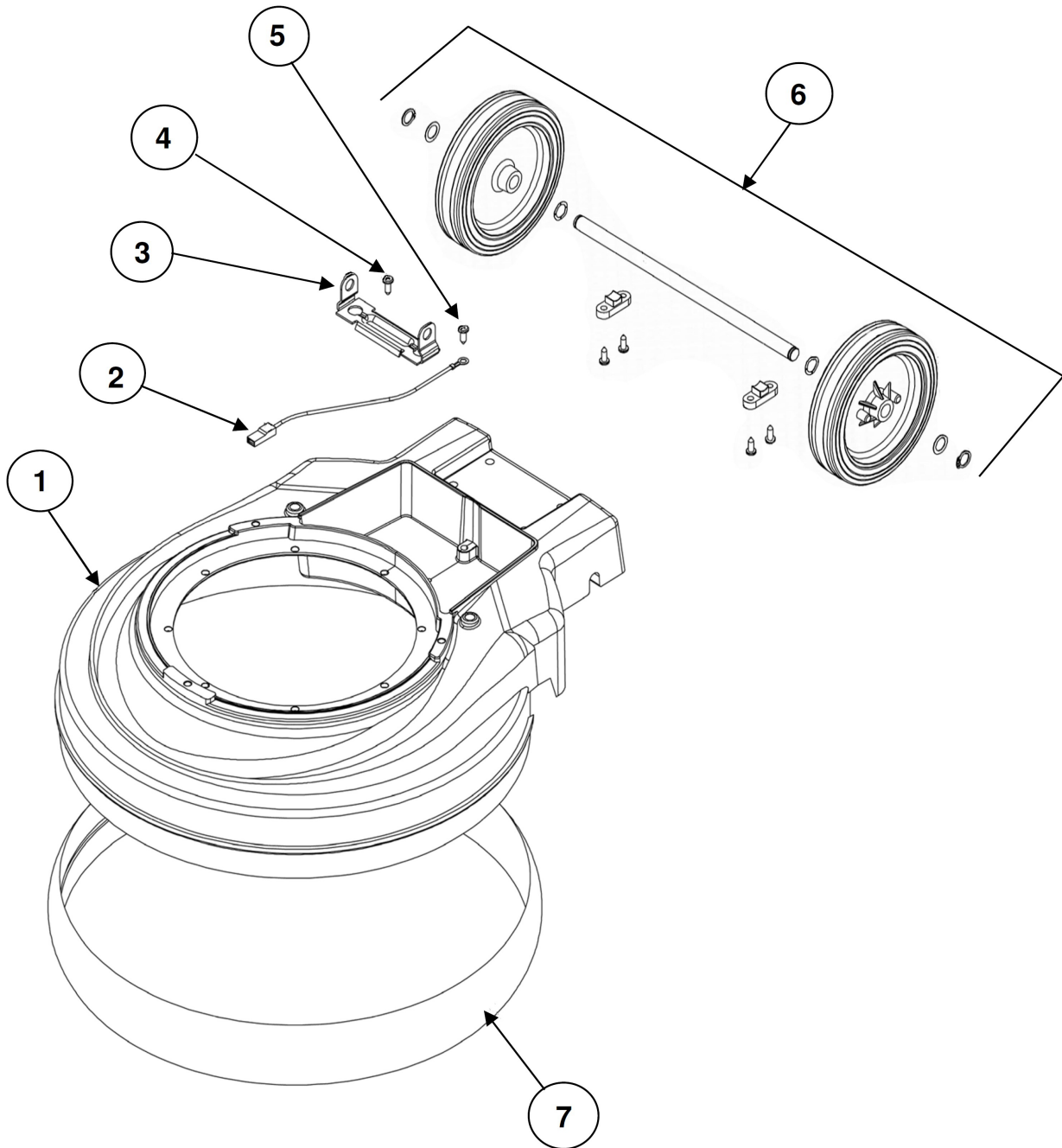

## 8 Chassis / Machine case

---

Item no.	Article no.	Description	Quantity
1	060273	Housing bottom part dark grey 2010	1
2	060255	Ground wire Samba 2010	1
3	060256	Holdig device condenser Samba 2010	1
4	015504	Lens head screw M5x10 DIN 7985	1
5		Screw 5x6	1
6	083950	Spare metal wheel set Samba	1
7	015358	Rubber bumpers light grey	1



## 9 Cleaning tank

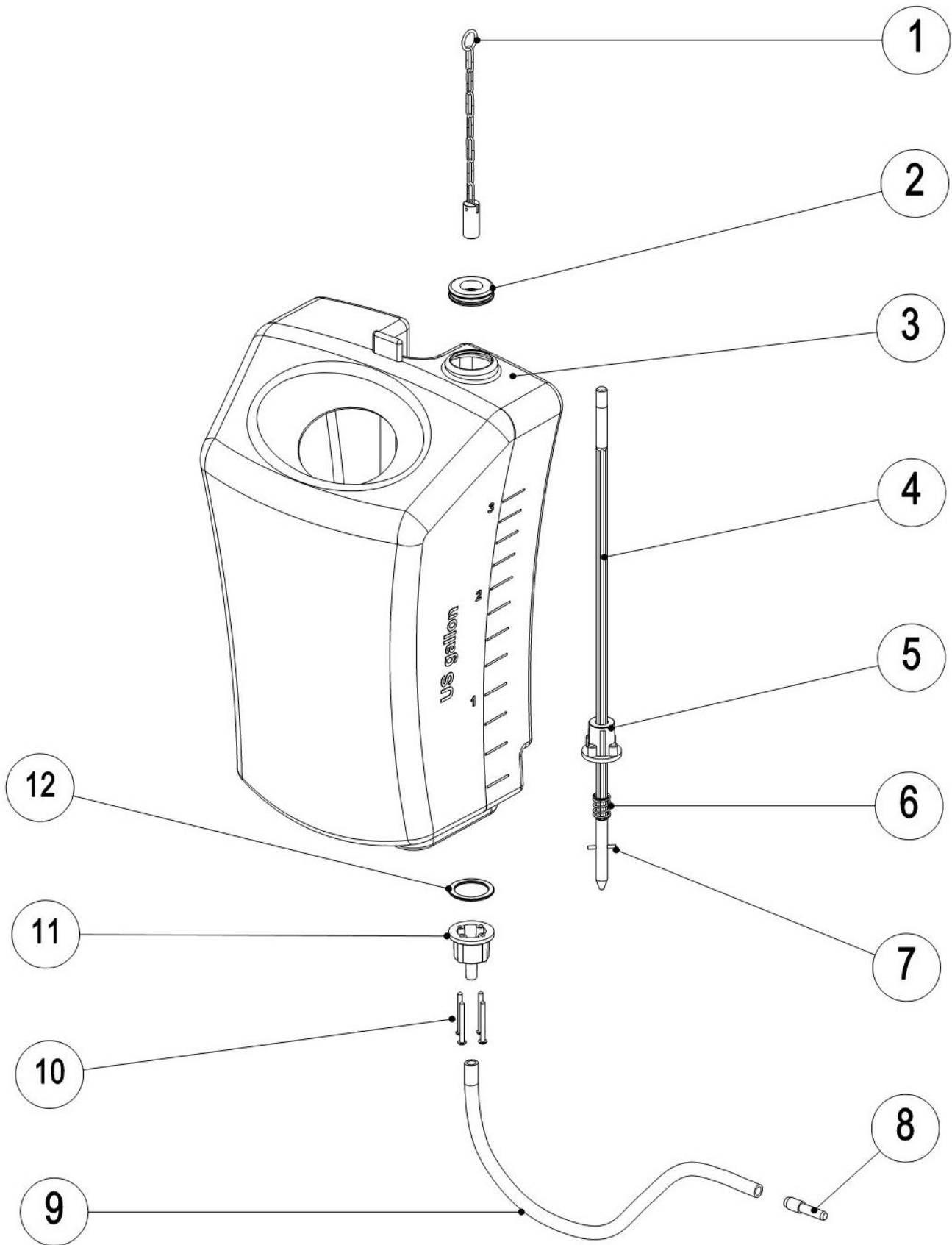

## 9 Cleaning tank

Item no.	Article no.	Description	Quantity
1	072889	Chain f.cleaning tank Samba	1
2		Sealing Top	1
3		Tank housing	1
4		Rod	1
5	017493	Half valve for W1700	1
6		Spring	1
7		Pin	1
8	018433	end fitting f.hose cleaning tank	1
9	018647	Hose for tank	1
10		Screw	4
11	017048	Lower half of valve	1
12		Sealing below	1
13	059831	Cleaning tank complete Samba 2010	1

## 10 Suction kit

---

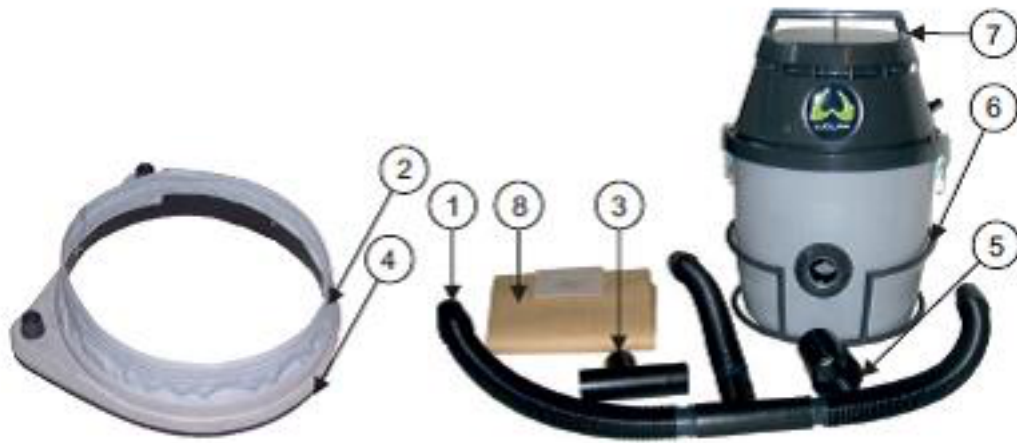

## 10 Suction kit

Item no.	Article no.	Description	Quantity
1	014038	Hose kit with T adapter	1
2	014039	Suction ring with sealing shell	1
3	015352	T-piece exhaust 390	1
4	015353	Brush ring f. suction kit	1
5	015354	Connecting piece f.exhaust 390	1
6	015355	Basket for Vacuum Samba/Tango	1
7	035082	Vacuum cleaner 230V/50Hz Samba/Tango	1
8	037299	Paper filter bags 80cm f.13503 5p/PU	1

## 11 Suction kit with bend

---



## 11 Suction kit with bend

---

Item no.	Article no.	Description	Quantity
1	035082	Vacuum cleaner 230V/50Hz Samba/Tango	1
2	073385	Connection hose cpl.	1
3	072462	Dust seal with elbow Samba	1
4	078742	Brush f. dust seal with elbow	1
5	072465	Bumper dust proof ring Samba	1

## 12 Electronic circuit diagram

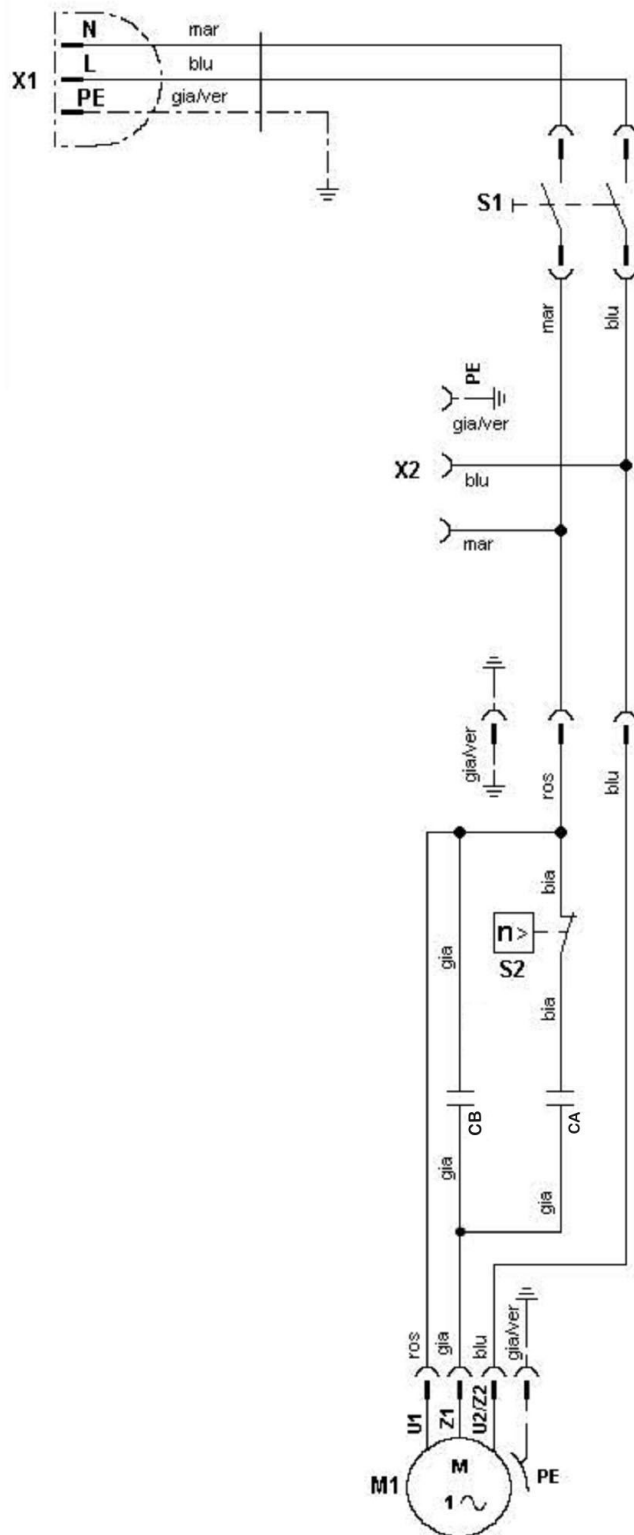

<b>GB</b>	<b>CB</b> OPERATING CAPACITOR
	<b>CA</b> START CAPACITOR
	<b>S2</b> TACHOMETRIC START CAPACITOR
	<b>M1</b> BRUSH ELECTRIC MOTOR
	<b>S1</b> MAIN POWER SWITCH
	<b>X1</b> POWER PLUG
	<b>X2</b> AUXILIAR SOCKET

ros	rosso	red
bia	bianco	white
mar	marrone	brown
blu	blu	blue
gia	giallo	yellow
ver	verde	green

## 12 Electronic circuit diagram

---