



spare parts list

Parkettnutfräse EU

Table of contents

1 Parkettnutfräse 230V EU (0001/2012 - heute)	3
1 Base support	5
2 Machine	7
1 Motor 230V Fräs junior 2010	10
3 Circuit diagram	13
4 Accessories	15

1 Parkettnutfräse 230V EU (0001/2012 - heute)

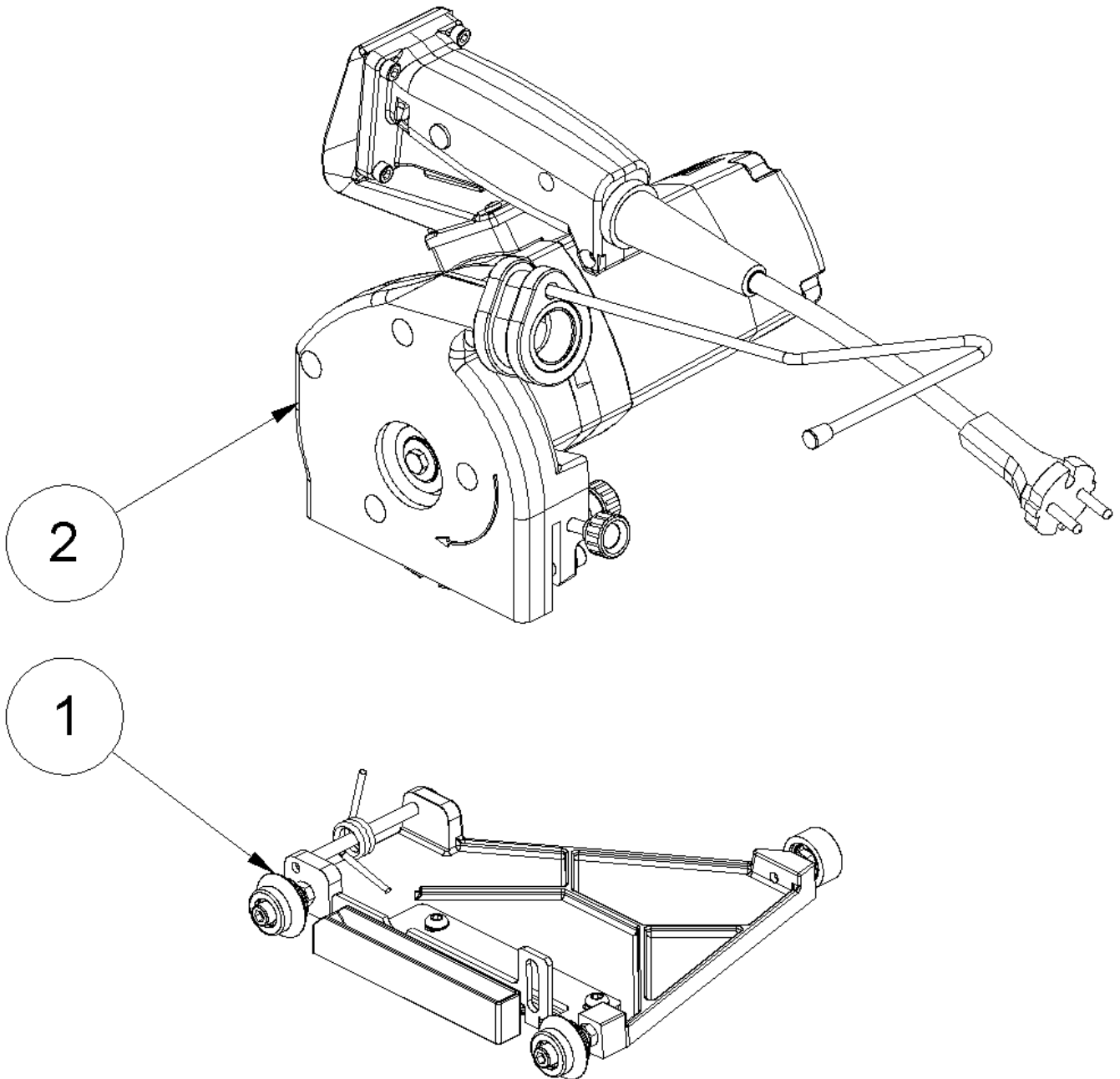

1 Parkettnutfräse 230V EU (0001/2012 - heute)

Item no.	Article no.	Description
1	01_01_067323	Base support
2	05_02_056092	Machine
3	01_03_056092	Circuit diagram
4	01_04_013489	Accessories

1 Base support

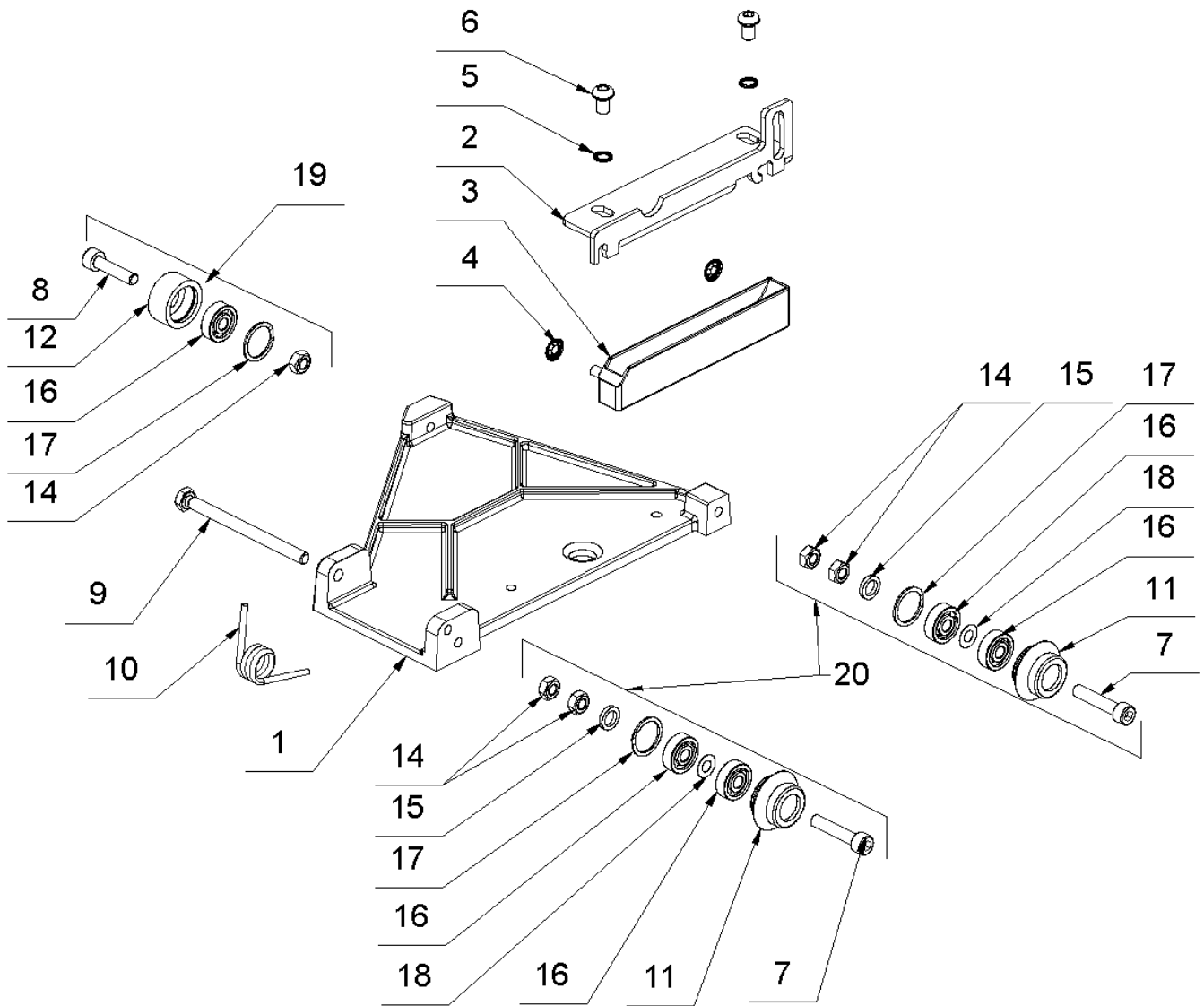

1 Base support

Item no.	Article no.	Description	Quantity
1	066702	Base plate Fräsjunior 2012	1
2	034331	Holder Span Protection Fräsjunior	1
3	017649	Span protection Fräsmaster	1
4	017776	Starlock Ø5 without cap	2
5	014859	Schnorr washer M6	2
6	014799	Lens head screw M6x10	2
7	017678	Cylinder head screw M6x30 DIN 912	2
8	014731	Cylinder head screw M6x25 DIN 912	1
9	017546	hexagon head screw M 6x 80 DIN 931	1
10	017641	Leg spring	1
11	067324	Guide roller 90° Biscuit joiner	2
12	017958	Roller SM1200/SM800	1
14	014809	Hexagon nut M6 DIN 934	5
15	163234	Spacer ring 8x12x2 parquet groove cutter	2
16	017538	Ball bearing DIN625-626 6x19x6 2RS	5
17	165045	Locking ring XDNH-19	3
18	018076	Shim washer 6x12x0,2 DIN 988	2
19	015041	Roller complete	1
20	067325	guide roller 90° cpl. Parkettnutfräse	2

2 Machine

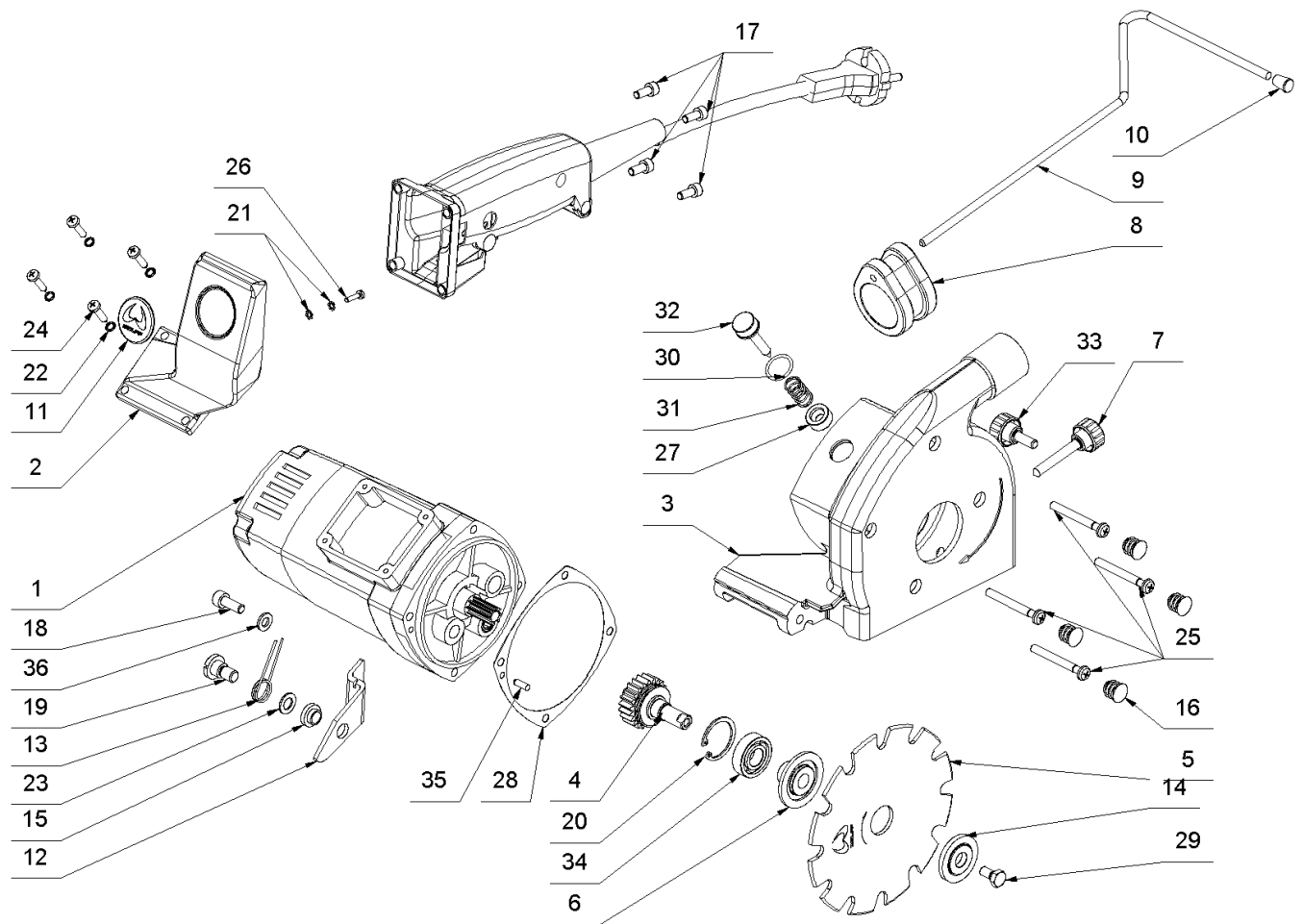

2 Machine

Item no.	Article no.	Description	Quantity
1	056241	Motor 230V Fräsjunior 2010	1
2	066703	Sized supports Fräsjunior 2012	1
3	066701	Hood Fräsjunior 2012	1
4	036117	Transmission shaft cpl. Fräsjunior	1
5	063011	Grooving disc 130x20x9 pointed Z 6	1
6	015311	Tool flange SM1200/SM800	1
7	017534	Knurled screw M6x40 DIN591	1
8	017626	Chip bag flange Fräsmaster	1
9	065741	Shackle short	1
10	017438	End cap	1
11	125896	Label Wolff 3D Ø30mm	1
12	034333	Swing arm Fräsjunior	1
13	035804	Spring clip Fräsjunior 2005	1
14	034094	Tension flange	1
15	034328	Spacer sleeve Fräsjunior	1
16	068566	Stopper Ø13,0x0,75 black	4
17	017742	Cylinder head screw M 5x14 DIN 912	4
18	014729	Cylinder head screw M 6x16 DIN 912	1
19	017716	Flat head screw M8x 6 DIN 923	1
20	017691	Circlip washer I28 DIN 472	1
21	017663	Tooth lock washer 4.3 Form A DIN 6797	2
22	016961	Snorr washer M4	4
23	017656	Shim ring 8x14x1 DIN 988	1
24	035800	Selftapping convex head screw F/H4,2x19	4
25	035801	Spax cap head 5x70	4
26	017473	Cylinder head screw M4x8 DIN 84 brass	1
27	017755	Sealing ring A 6x16x7 NBR/3760	1
28	018793	Gear block sealing Fräsmaster	1
29	015320	Hexagon screw M6 left	1
30	015278	O-ring for locking pin Fräsmaster	1
31	017749	Pressure spring 10x42,50x0,8	1
32	017959	Locking stud Fräsmaster	1
33	018760	Knurled screw M6x16	1
34	017539	Ball bearing 6001 2RS1	1

2 Machine

Item no.	Article no.	Description	Quantity
35	017740	Cylindrical pin 4x12 DIN 6325	1
36	014827	Washer M6 DIN 125 A	1
o.Abb	059184	Plug Adapter 3-pole 230V CH T12	1
o.Abb	078293	Plug Adapter UK 230V SK1 3-polig	1
o.Abb	084419	Plug 3-pole Heavy Duty 10A AUS	1
o.Abb	078966	Adapter Plug 3-pol. 230V 10A DK	1

1 Motor 230V Fräsjunior 2010

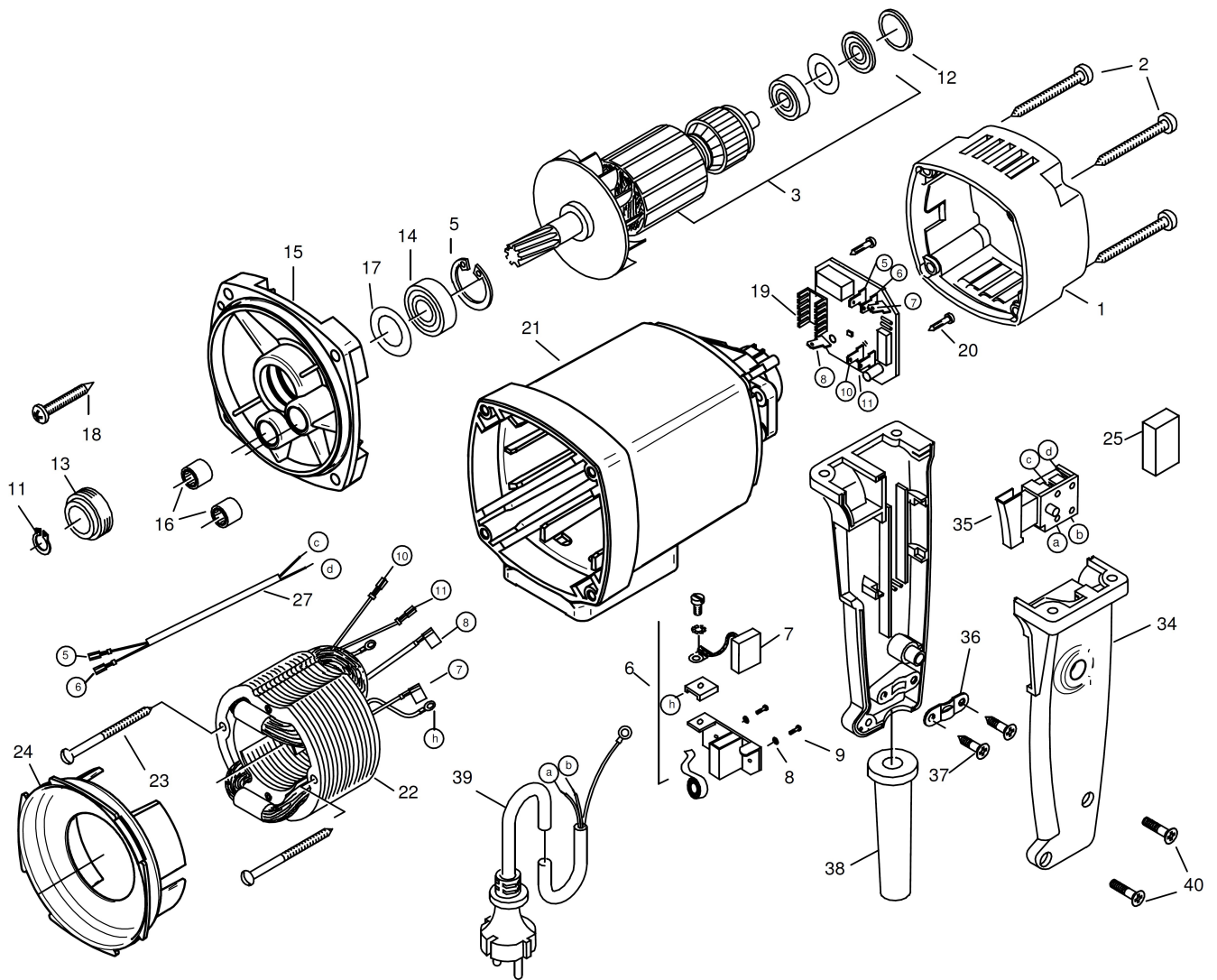

1 Motor 230V Fräsjunior 2010

Item no.	Article no.	Description	Quantity
1	019030	Cap (Motor) Fräsmaster	1
2		Metal bolt HC4,8x45	4
3		Edge runner, complete	1
5	012451	Locking ring motor AMW 1500/1501	1
6		Pocket brush holder	2
7	067639	Carbon brush Fräsjunior 230V	2
8		Spring washer	4
9		Thread forming screw CM4x12	4
11		Circlip 15/1	1
12		O-ring	1
13		Bolt seal	1
14		Ball bearing 6902-2Z	1
15	012244	Getriebelagerschild Motor AMW 1500/1501	1
16		Needle bush HK0810	1
17	012500	Shim ring motor AMW 1500/1501	1
18		Metal bolt HC 4,8x22	1
19	011987	Printed circuit board AMW1501 230V	1
20		Metal bolt HC2,9x13	2
21		Motor housing	1
22		Coil ring	1
23		Metal bolt C3,9x60	2
24	019029	Air ring Fräsmaster	1
25	018771	Anti-interference capacitor	1
27	011988	Switch wire AMW 1501 230V	1
34		Handle shell (without controller)	1
35	016949	Mounting switch Fräsmaster/Fräsjunior	1
36	017559	Cord grip	1
37		Metal bolt DIN7981-4.2x13	2
38	019024	Cable bushing Fräsmaster/Junior	1
39	019164	Câble d'alimentation 3G1.5x4m noir fiche	1
40	019540	Pan-head tapping screw 4.2x16 DIN 7981 C	2
o.Abb		Insulating tube	11
o.Abb		Interference suppressor capacitor	1
o.Abb	017412	Spindle wheel	1

1 Motor 230V Fräsjunior 2010

Item no.	Article no.	Description	Quantity
o.Abb	018793	Gear block sealing Fräsmaster	1

3 Circuit diagram

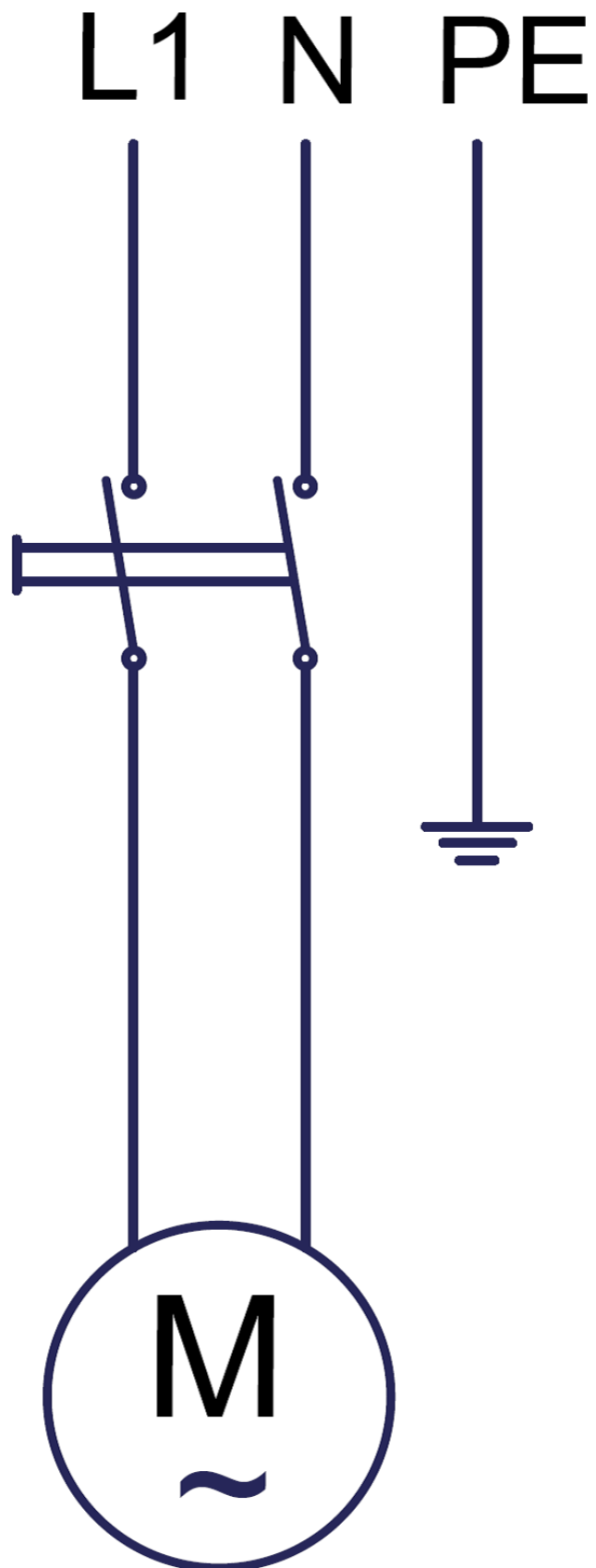

3 Circuit diagram

4 Accessories

Item no.	Article no.	Description	Quantity
1	015315	Hearing protectors	1
2	015316	Protective goggles	1
3	017612	Double fork wrench sw10/13 mm	1
4	014956	Hexagonal screw key SW5 DIN 911	1
5	068974	Dust bag short white SEE 10581	1
6	060926	Sleeve C35EL Starvac+PallmannDust	1
7	067326	Technical instructions Parkettnutfräse	1